

DES

- Introduction to DES
- Overview of the DES Algorithm
- Internal Structure of DES
- Decryption
- Security of DES

■ Classification of DES in the Field of Cryptology

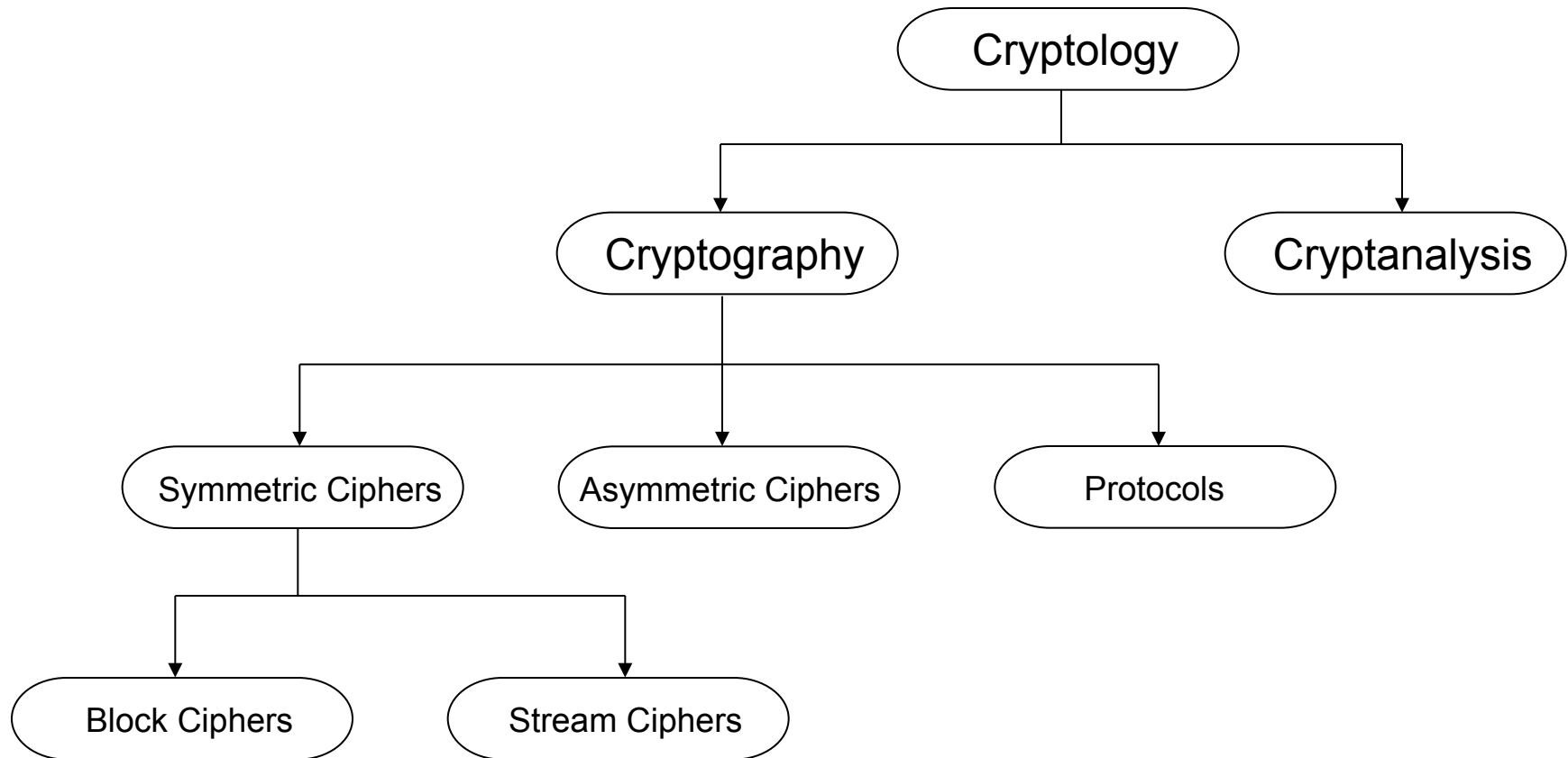

■ DES Facts

- Data Encryption Standard (DES) encrypts **blocks of size 64 bit**.
- Developed by **IBM** based on the cipher *Lucifer* under influence of the *National Security Agency* (NSA), the design criteria for DES have not been published
- **Standardized 1977** by the **National Bureau of Standards** (NBS) today called *National Institute of Standards and Technology* (NIST)
- Most popular **block cipher** for most of the last 30 years.
- By far best studied symmetric algorithm.
- Nowadays considered insecure due to the small **key length of 56 bit**.
- **But: 3DES yields very secure cipher**, still widely used today.
- Replaced by the *Advanced Encryption Standard* (**AES**) in 2000

■ Block Cipher Primitives: Confusion and Diffusion

- Claude Shannon: There are two primitive operations with which strong encryption algorithms can be built:
 - 1. Confusion:** An encryption operation where the **relationship between key and ciphertext is obscured**.
Today, a common element for achieving confusion is **substitution**, which is found in both AES and DES.
 - 2. Diffusion:** An encryption operation where the **influence of one plaintext symbol is spread over many ciphertext symbols** with the goal of hiding statistical properties of the plaintext.
A simple diffusion element is the **bit permutation**, which is frequently used within DES.
- Both operations by themselves cannot provide security. The idea is to concatenate confusion and diffusion elements to build so called *product ciphers*.

■ Product Ciphers

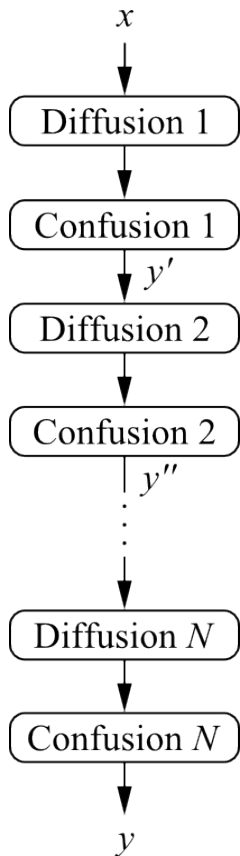

- Most of today's block ciphers are *product ciphers* as they consist of rounds which are applied repeatedly to the data.
- Can reach excellent diffusion: **changing of one bit of plaintext results on average in the change of half the output bits.**

Example:

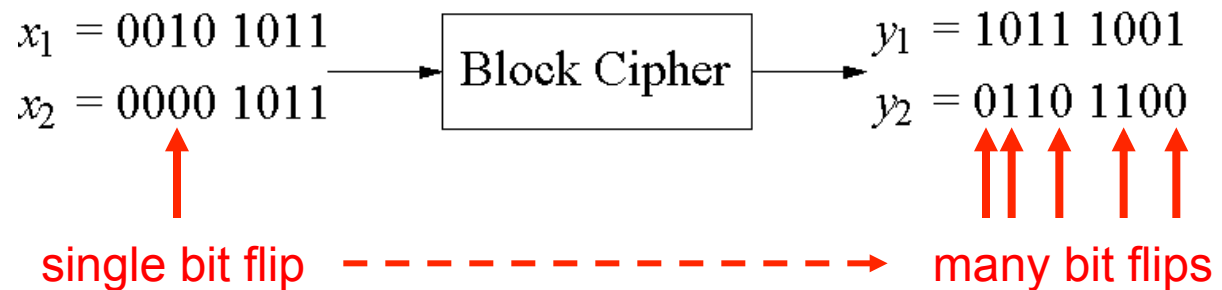

■ Overview of the DES Algorithm

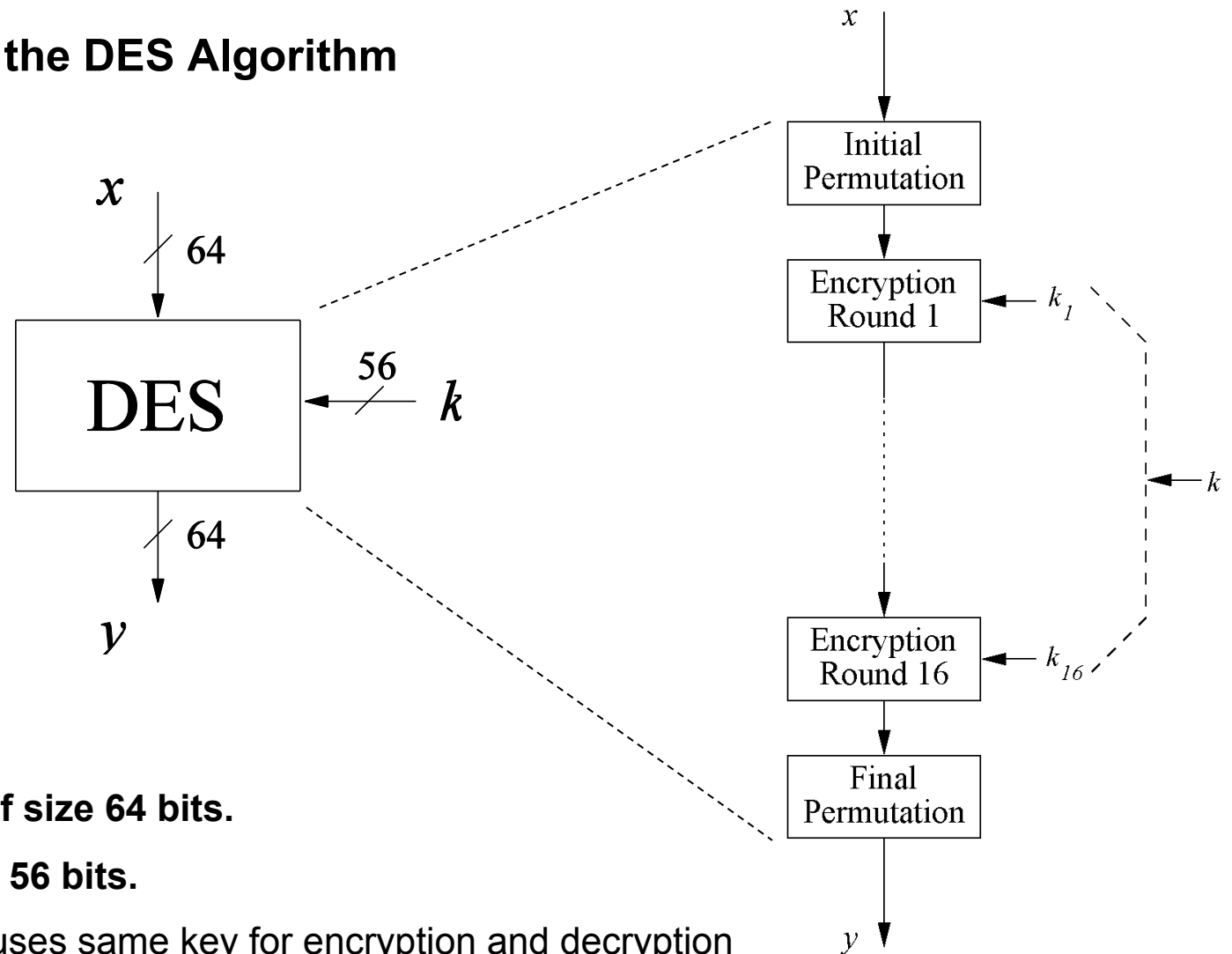

- **Encrypts blocks of size 64 bits.**
- **Uses a key of size 56 bits.**
- Symmetric cipher: uses same key for encryption and decryption
- Uses 16 rounds which all perform the identical operation
- Different subkey in each round derived from main key

■ The DES Feistel Network (1)

- DES structure is a *Feistel network*
- Advantage: encryption and decryption differ only in keyschedule

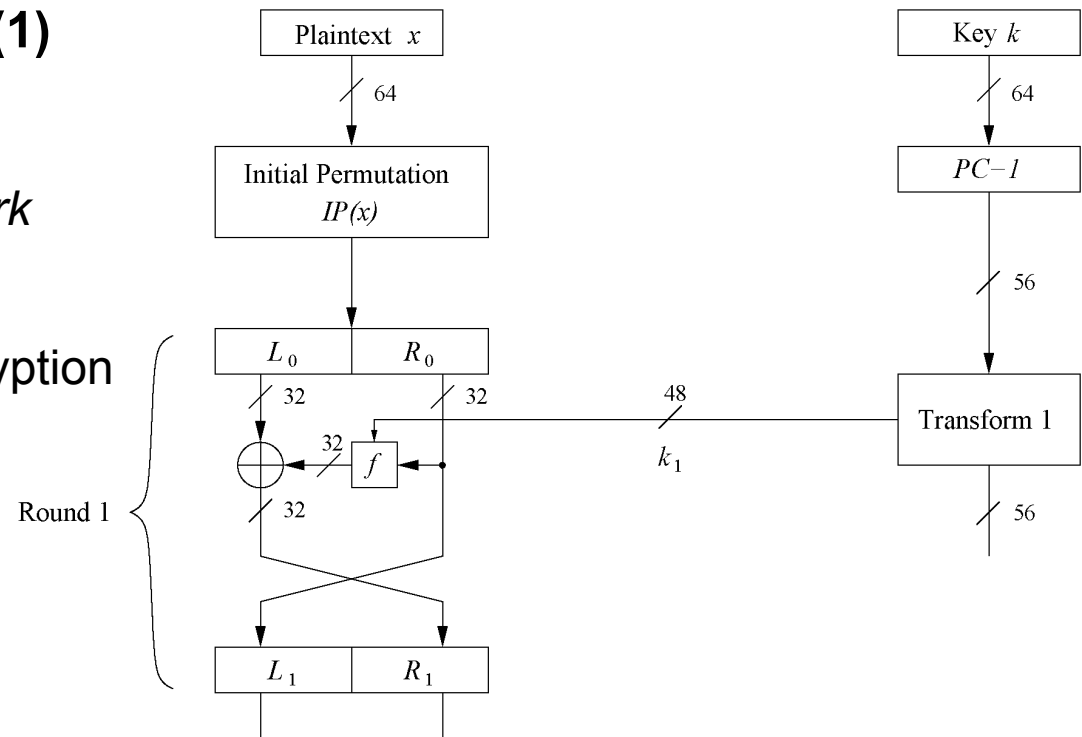

- Bitwise initial permutation, then 16 rounds
 1. Plaintext is split into 32-bit halves L_i and R_i
 2. R_i is fed into the function f , the output of which is then XORed with L_i
 3. Left and right half are swapped
- Rounds can be expressed as:

$$L_i = R_{i-1},$$

$$R_i = L_{i-1} \oplus f(R_{i-1}, k_i)$$

■ The DES Feistel Network (2)

- L and R swapped again at the end of the cipher, i.e., after round 16 followed by a final permutation

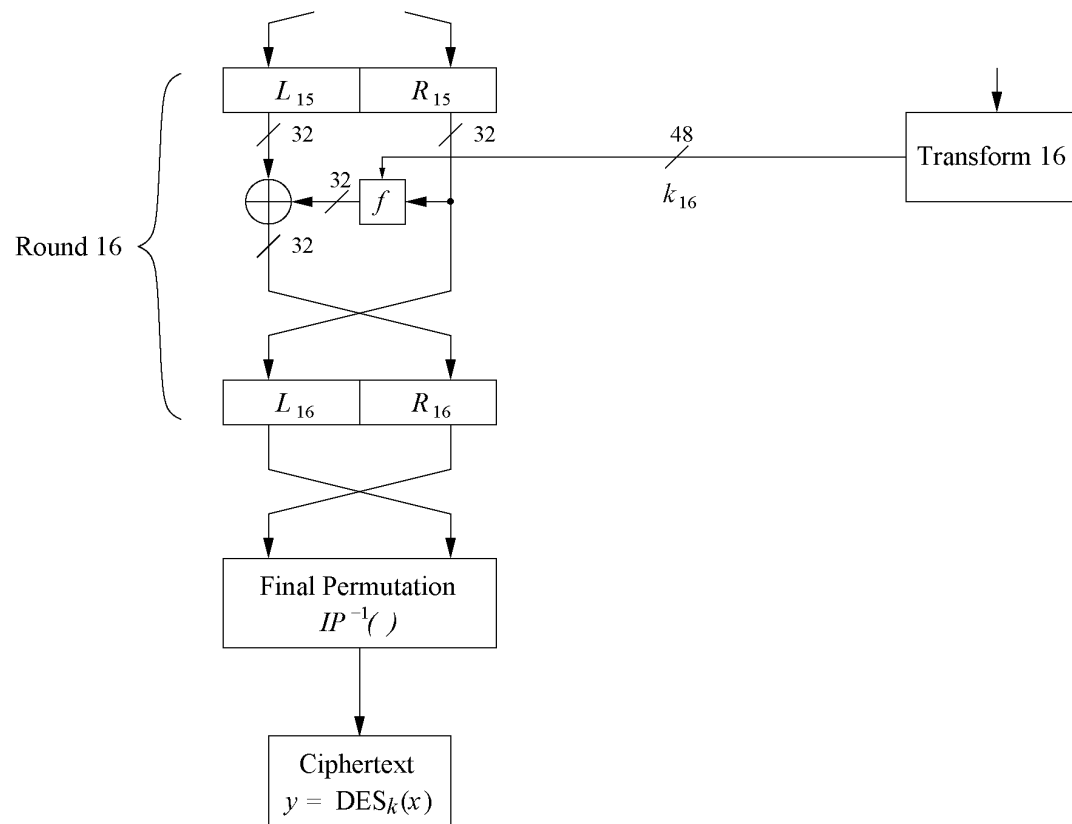

■ Initial and Final Permutation

- Bitwise Permutations.
- Inverse operations.
- Described by tables IP and IP^{-1} .

Initial Permutation

IP							
58	50	42	34	26	18	10	2
60	52	44	36	28	20	12	4
62	54	46	38	30	22	14	6
64	56	48	40	32	24	16	8
57	49	41	33	25	17	9	1
59	51	43	35	27	19	11	3
61	53	45	37	29	21	13	5
63	55	47	39	31	23	15	7

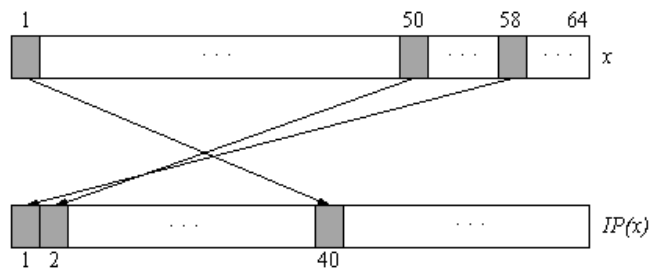

Final Permutation

IP^{-1}							
40	8	48	16	56	24	64	32
39	7	47	15	55	23	63	31
38	6	46	14	54	22	62	30
37	5	45	13	53	21	61	29
36	4	44	12	52	20	60	28
35	3	43	11	51	19	59	27
34	2	42	10	50	18	58	26
33	1	41	9	49	17	57	25

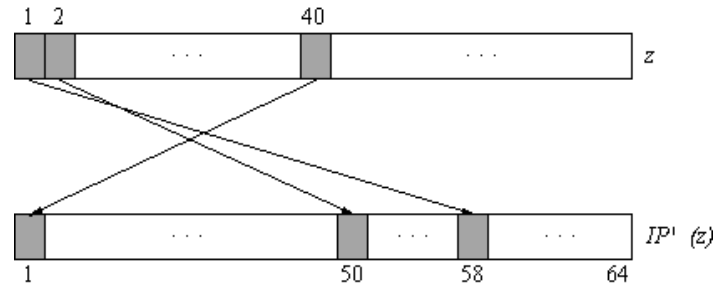

■ The f-Function

- main operation of DES
- f -Function inputs:
 R_{i-1} and round key k_i
- 4 Steps:
 1. Expansion E
 2. XOR with round key
 3. S-box substitution
 4. Permutation

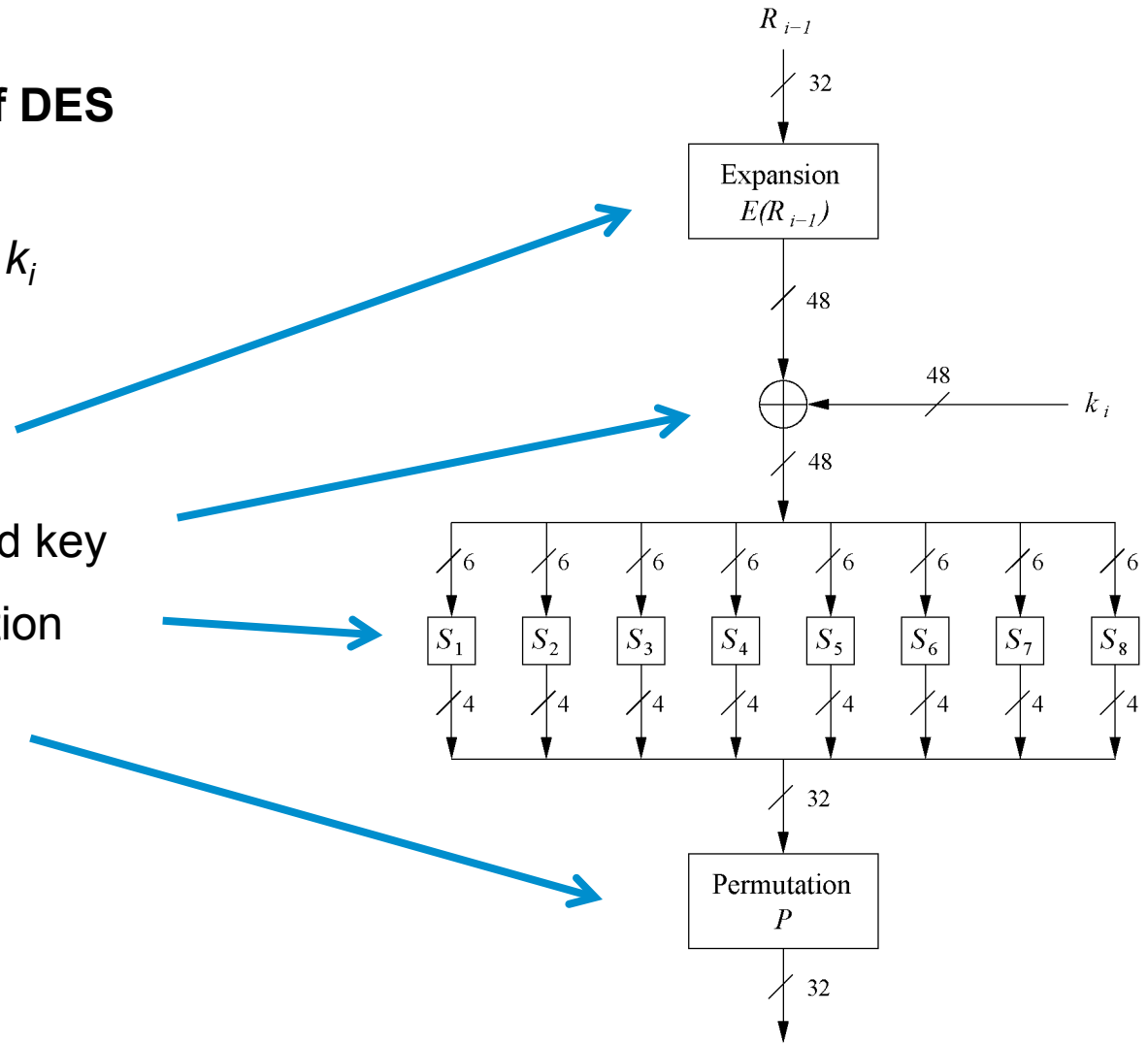

■ The Expansion Function E

1. Expansion E

- main purpose:
increases diffusion

<i>E</i>	
32	1 2 3 4 5
4	5 6 7 8 9
8	9 10 11 12 13
12	13 14 15 16 17
16	17 18 19 20 21
20	21 22 23 24 25
24	25 26 27 28 29
28	29 30 31 32 1

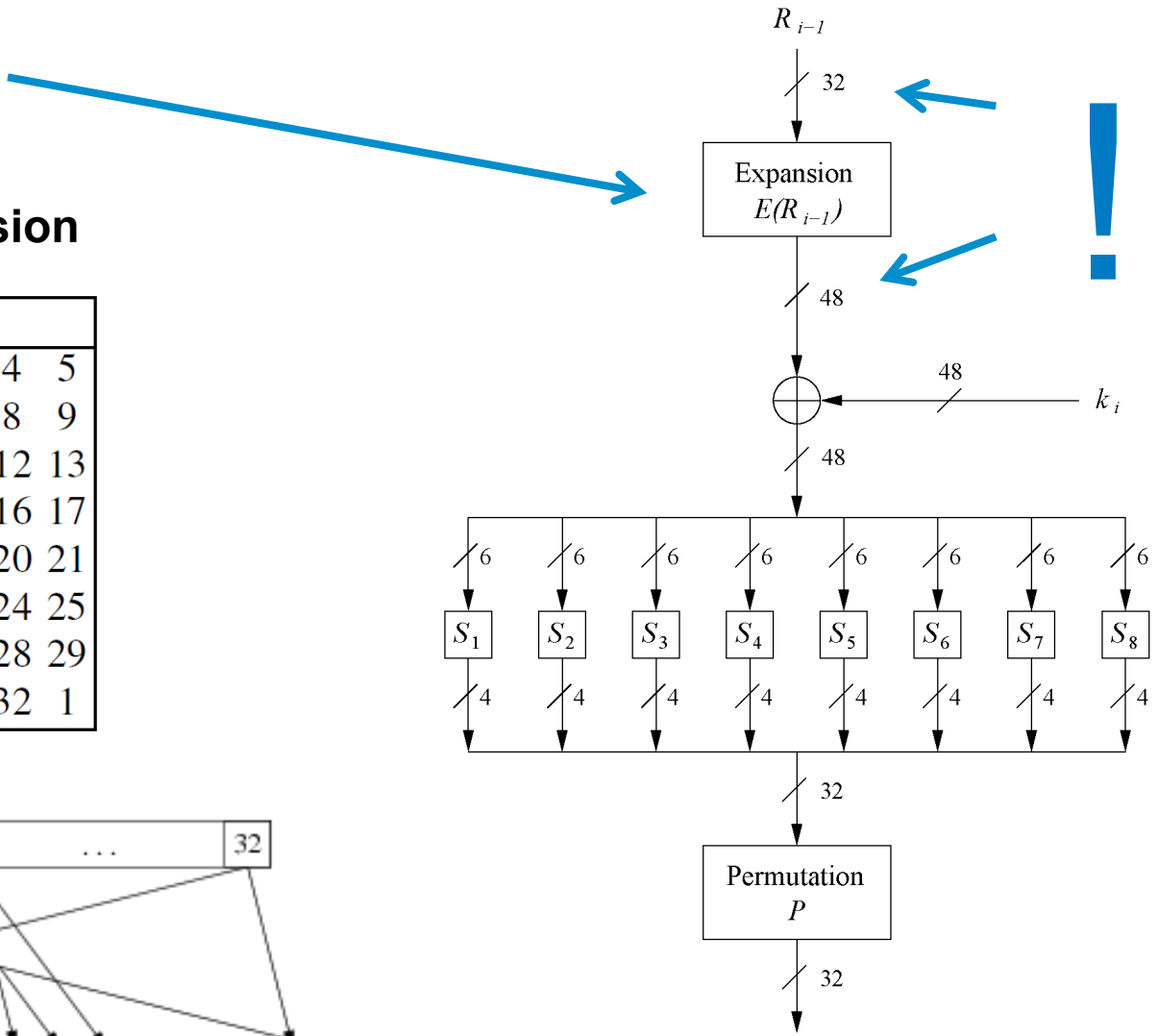
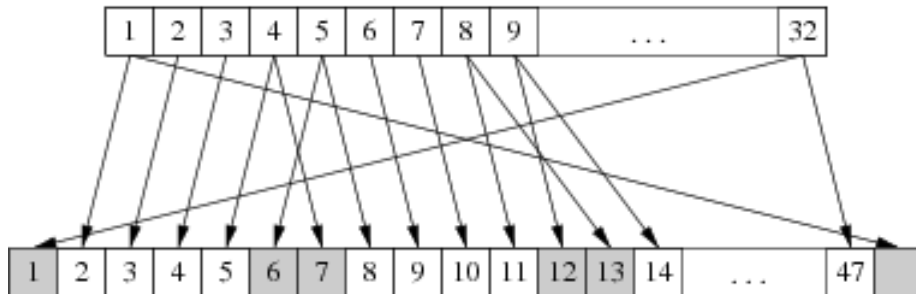

■ Add Round Key

2.XOR Round Key

- Bitwise XOR of the round key and the output of the expansion function

E

- Round keys are derived from the main key in the DES keyschedule (in a few slides)

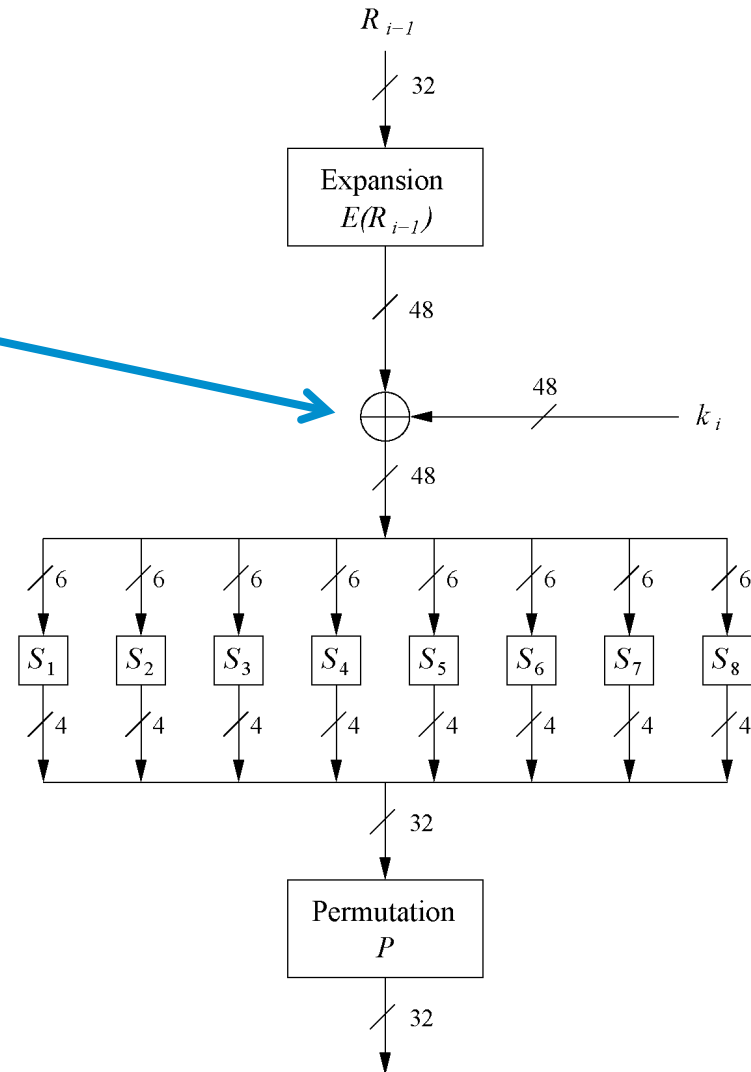

■ The DES S-Boxes

3.S-Box substitution

- Eight substitution tables.
- 6 bits of input, 4 bits of output.
- Non-linear and resistant to differential cryptanalysis.
- Crucial element for DES security!

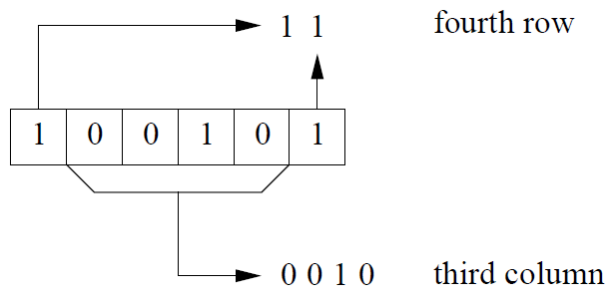

S_1	0	1	2	3	4	5	6	7	8	9	10	11	12	13	14	15
0	14	04	13	01	02	15	11	08	03	10	06	12	05	09	00	07
1	00	15	07	04	14	02	13	01	10	06	12	11	09	05	03	08
2	04	01	14	08	13	06	02	11	15	12	09	07	03	10	05	00
3	15	12	08	02	04	09	01	07	05	11	03	14	10	00	06	13

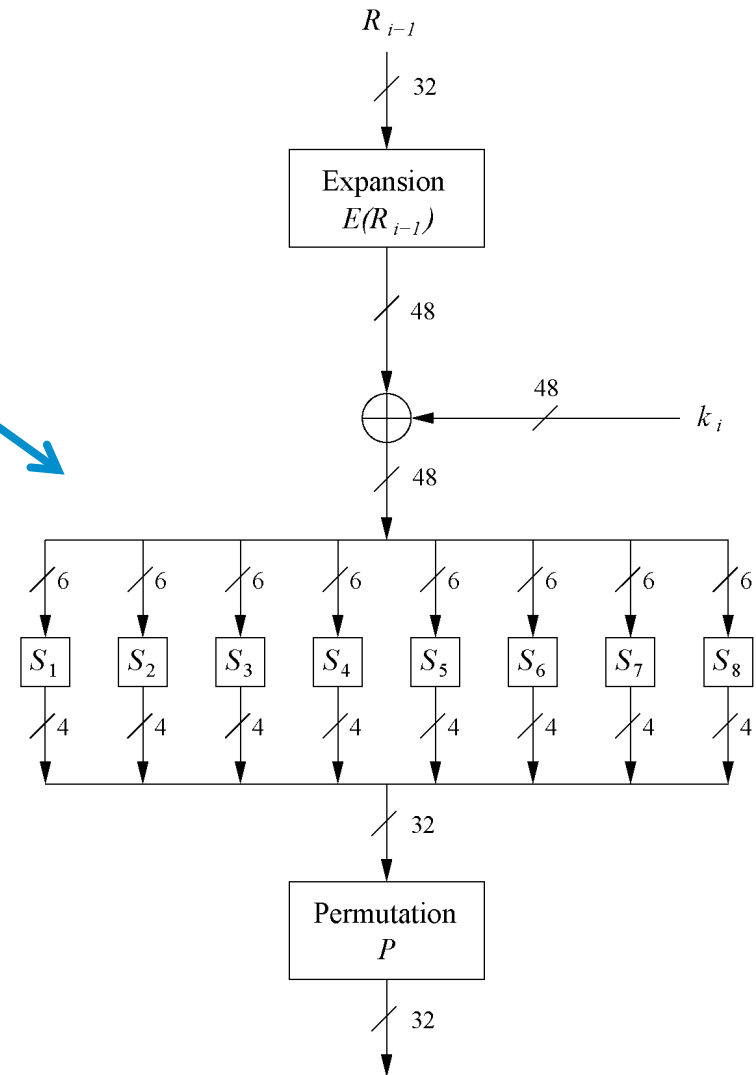

■ The Permutation P

4. Permutation P

- Bitwise permutation.
- Introduces diffusion.
- Output bits of one S-Box effect several S-Boxes in next round
- Diffusion by E, S-Boxes and P guarantees that after Round 5 every bit is a function of each key bit and each plaintext bit.

P							
16	7	20	21	29	12	28	17
1	15	23	26	5	18	31	10
2	8	24	14	32	27	3	9
19	13	30	6	22	11	4	25

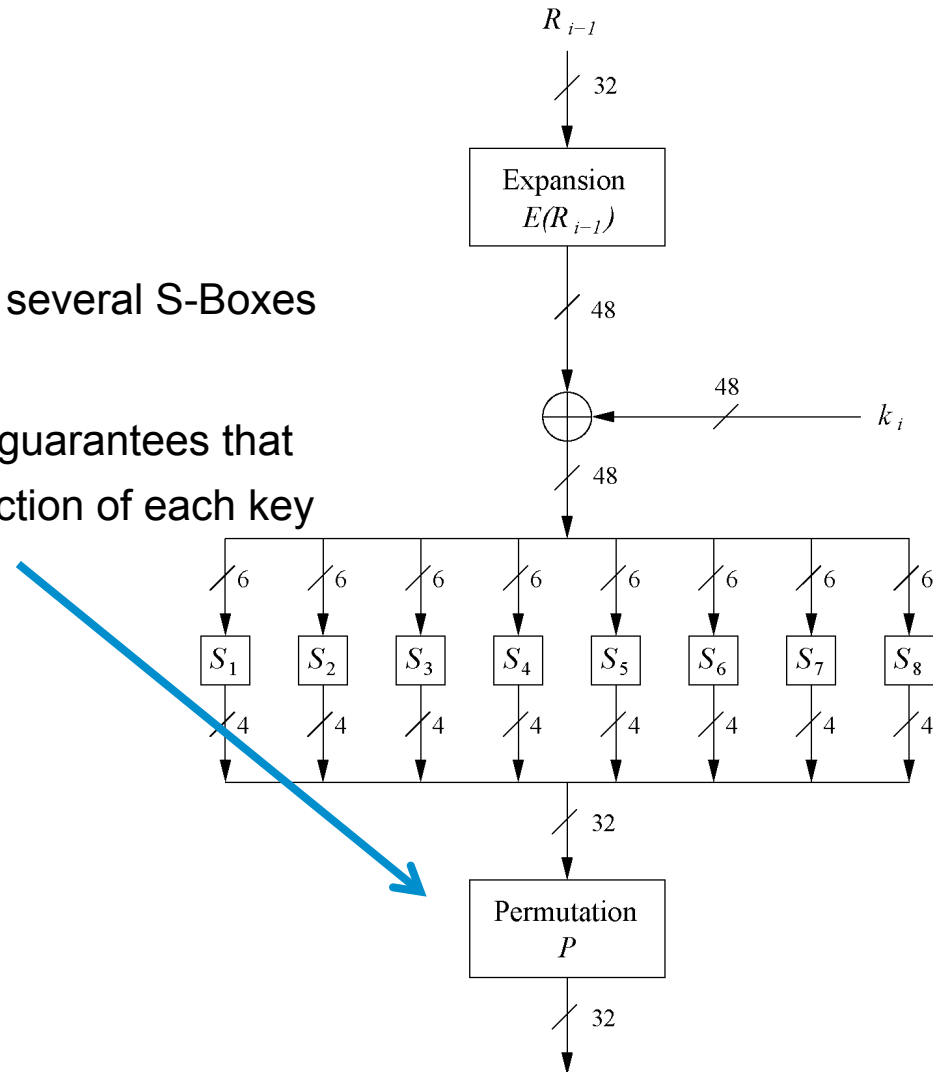

■ Key Schedule (1)

- Derives 16 round keys (or *subkeys*) k_i of 48 bits each from the original 56 bit key.
- The input key size of the DES is 64 bit. **56 bit key** and 8 bit parity:

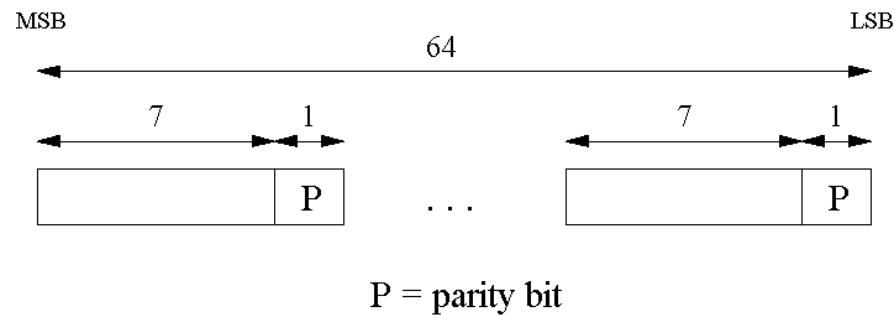

- **Parity bits are removed** in a first **permuted choice $PC-1$** :
(note that the bits 8, 16, 24, 32, 40, 48, 56 and 64 are not used at all)

$PC - 1$							
57	49	41	33	25	17	9	1
58	50	42	34	26	18	10	2
59	51	43	35	27	19	11	3
60	52	44	36	63	55	47	39
31	23	15	7	62	54	46	38
30	22	14	6	61	53	45	37
29	21	13	5	28	20	12	4

■ Key Schedule (2)

- Split key into 28-bit halves C_0 and D_0 .
- In **rounds $i = 1, 2, 9, 16$** , the two halves are each rotated left by **one bit**.
- In **all other rounds** where the two halves are each rotated left by **two bits**.
- In each round i permuted choice **PC-2** selects a permuted subset of 48 bits of C_i and D_i as round key k_i , i.e. **each k_i is a permutation of k !**

PC-2							
14	17	11	24	1	5	3	28
15	6	21	10	23	19	12	4
26	8	16	7	27	20	13	2
41	52	31	37	47	55	30	40
51	45	33	48	44	49	39	56
34	53	46	42	50	36	29	32

- **Note:** The total number of rotations:
 $4 \times 1 + 12 \times 2 = 28 \Rightarrow D_0 = D_{16}$ and $C_0 = C_{16}$!

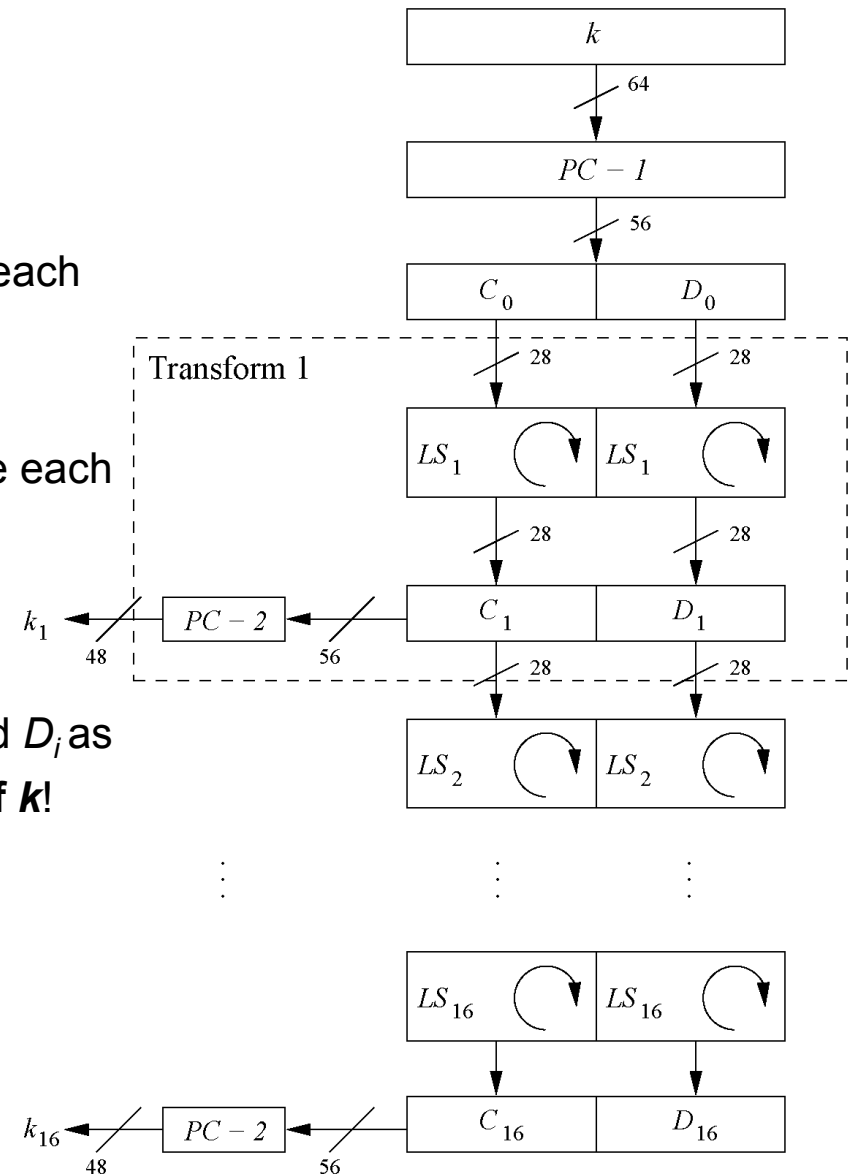

■ Decryption

- In **Feistel ciphers** only the keyschedule has to be modified for decryption.
- Generate the same 16 round keys in reverse order.
- **Reversed key schedule:**
As $D_0=D_{16}$ and $C_0=C_{16}$ the first round key can be generated by applying $PC-2$ right after $PC-1$ (no rotation here!). All other rotations of C and D can be reversed to reproduce the other round keys resulting in:
 - No rotation in round 1.
 - One bit rotation **to the right** in rounds 2, 9 and 16.
 - Two bit rotations **to the right** in all other rounds.

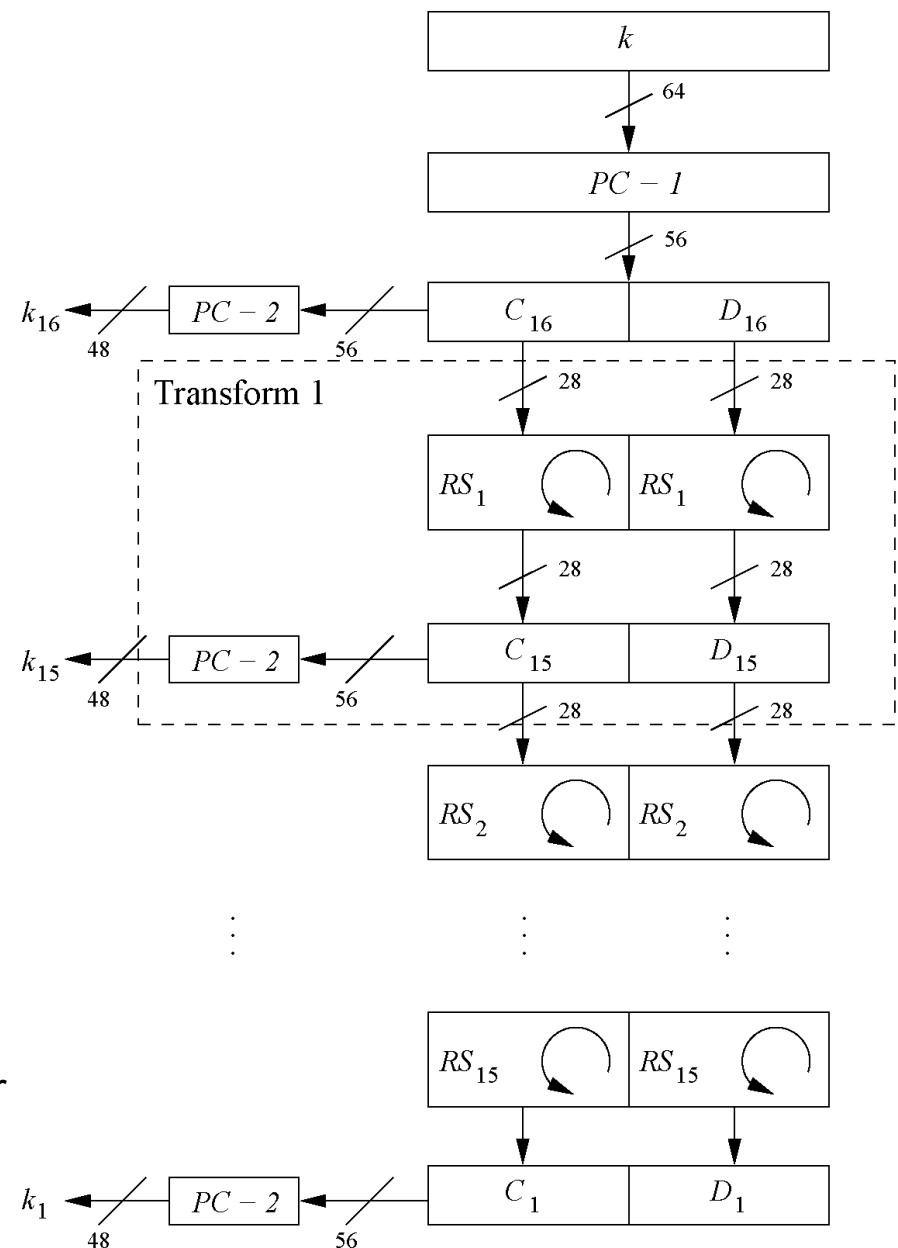

■ Security of DES

- **After proposal of DES two major criticisms arose:**
 1. Key space is too small (2^{56} keys)
 2. S-box design criteria have been kept secret: Are there any hidden analytical attacks (*backdoors*), only known to the NSA?
- **Analytical Attacks:** DES is highly resistant to both *differential* and *linear cryptanalysis*, which have been published years later than the DES. This means IBM and NSA had been aware of these attacks for 15 years!
So far there is no known analytical attack which breaks DES in realistic scenarios.
- **Exhaustive key search:** For a given pair of plaintext-ciphertext (x, y) test all 2^{56} keys until the condition $\text{DES}_k^{-1}(x)=y$ is fulfilled.
⇒ Relatively easy given today's computer technology!

■ History of Attacks on DES

Year	Proposed/ implemented DES Attack
1977	Diffie & Hellman, (under-)estimate the costs of a key search machine
1990	Biham & Shamir propose differential cryptanalysis (2^{47} chosen ciphertexts)
1993	Mike Wiener proposes design of a very efficient key search machine: Average search requires 36h. Costs: \$1.000.000
1993	Matsui proposes linear cryptanalysis (2^{43} chosen ciphertexts)
Jun. 1997	DES Challenge I broken, 4.5 months of distributed search
Feb. 1998	DES Challenge II--1 broken, 39 days (distributed search)
Jul. 1998	DES Challenge II--2 broken, key search machine <i>Deep Crack</i> built by the Electronic Frontier Foundation (EFF): 1800 ASICs with 24 search engines each, Costs: \$250 000, 15 days average search time (required 56h for the Challenge)
Jan. 1999	DES Challenge III broken in 22h 15min (distributed search assisted by <i>Deep Crack</i>)
2006-2008	Reconfigurable key search machine <i>COPACOBANA</i> developed at the Universities in Bochum and Kiel (Germany), uses 120 FPGAs to break DES in 6.4 days (avg.) at a cost of \$10 000.

■ Triple DES – 3DES

- Triple encryption using DES is often used in practice to extend the effective key length of DES to 112.

$$y = DES_{k_3}(DES_{k_2}(DES_{k_1}(x)))$$

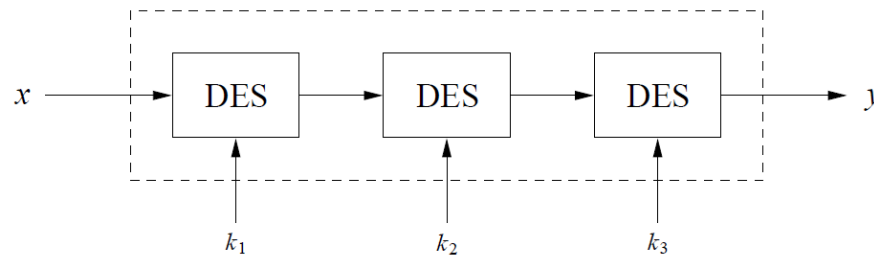

- Alternative ver

Advantage: choosing $k_1=k_2=k_3$ $y = DES_{k_3}(DES_{k_2}^{-1}(DES_{k_1}(x)))$.

- No practical attack known today.
- Used in many legacy applications, i.e., in banking systems.

■ Alternatives to DES

Algorithm	I/O Bit	key lengths	remarks
AES / Rijndael	128	128/192/256	DES "replacement", worldwide used standard
Triple DES	64	112 (effective)	conservative choice
Mars	128	128/192/256	AES finalist
RC6	128	128/192/256	AES finalist
Serpent	128	128/192/256	AES finalist
Twofish	128	128/192/256	AES finalist
IDEA	64	128	patented

■ Lessons Learned

- DES was the dominant symmetric encryption algorithm from the mid-1970s to the mid-1990s. Since 56-bit keys are no longer secure, the Advanced Encryption Standard (AES) was created.
- Standard DES with 56-bit key length can be broken relatively easily nowadays through an exhaustive key search.
- DES is quite robust against known analytical attacks: In practice it is very difficult to break the cipher with differential or linear cryptanalysis.
- By encrypting with DES three times in a row, triple DES (3DES) is created, against which no practical attack is currently known.
- The “default” symmetric cipher is nowadays often AES. In addition, the other four AES finalist ciphers all seem very secure and efficient.