

Artificial Intelligence

CS 165A

Apr 25, 2023

Instructor: Prof. Yu-Xiang Wang

T
o
d
a
y

- Finish up PGM
- Problem Solving by Search
- Search algorithms

Logistics

- Project 1 due this Thursday 11:59 pm
 - the bonus part and the report is due by midterm (in another week)
 - Check Ed Discussion for announcements
- Instructor OH at 2pm today
 - A poll on Ed Discussion on your availability to the Ohs
- Homework 2 and Ed Quiz posted.
 - Practice on BayesNets and conditional independence readings

Recap of the last lecture

- Three steps in modelling with Bayesian networks
- Inference with Bayesian networks using only CPTs
- Three equivalent ways of describing structures of a joint distribution
 - Factorization \Leftrightarrow DAG \Leftrightarrow the set of conditional independences
- Prove conditional independence by definition.

Recap of the last lecture

- Reading conditional independences from the DAG itself.
- d-separation
 - Three canonical graphs

Recap: d-separation in three canonical graphs

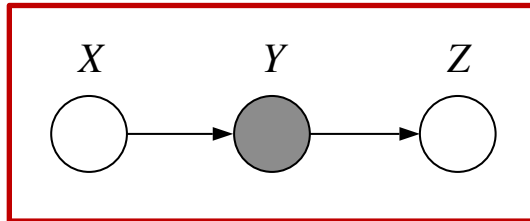
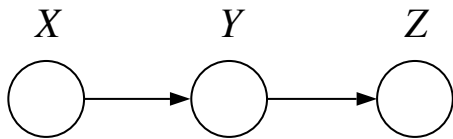

$$X \perp Z \mid Y$$

“**Chain:** X and Z are d-separated by the observation of Y.”

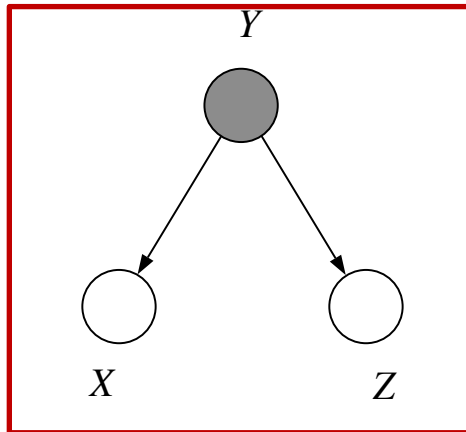
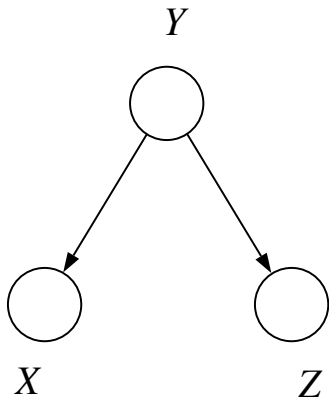

$$X \perp Z \mid Y$$

“**Fork:** X and Z are d-separated by the observation of Y.”

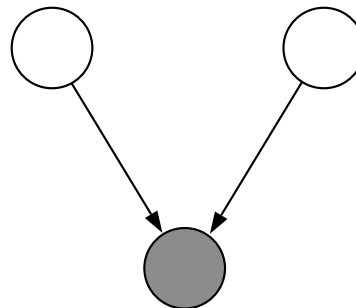
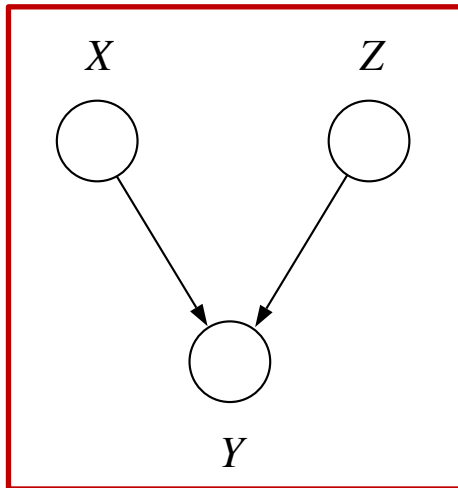

$$X \not\perp Z$$

“**Collider:** X and Z are d-separated by NOT observing Y **nor any descendants** of Y.”

Today

- Bayes Ball Algorithm for determining conditional independences in a general BayesNet
- “Markov Blanket” and pointers for learning more about PGMs
- Start “Search Agent”
 - Problem solving by search
 - Basic Algorithm for Search

The Bayes Ball algorithm

- Let \mathbf{X} , \mathbf{Y} , \mathbf{Z} be “*groups*” of nodes / set / subgraphs.
- Shade nodes in \mathbf{Y}
- Place a “ball” at each node in \mathbf{X}
- Bounce balls around the graph according to **rules**
- If no ball reaches any node in \mathbf{Z} , then declare

$$\mathbf{X} \perp \mathbf{Z} \mid \mathbf{Y}$$

The Ten Rules of Bayes Ball Algorithm

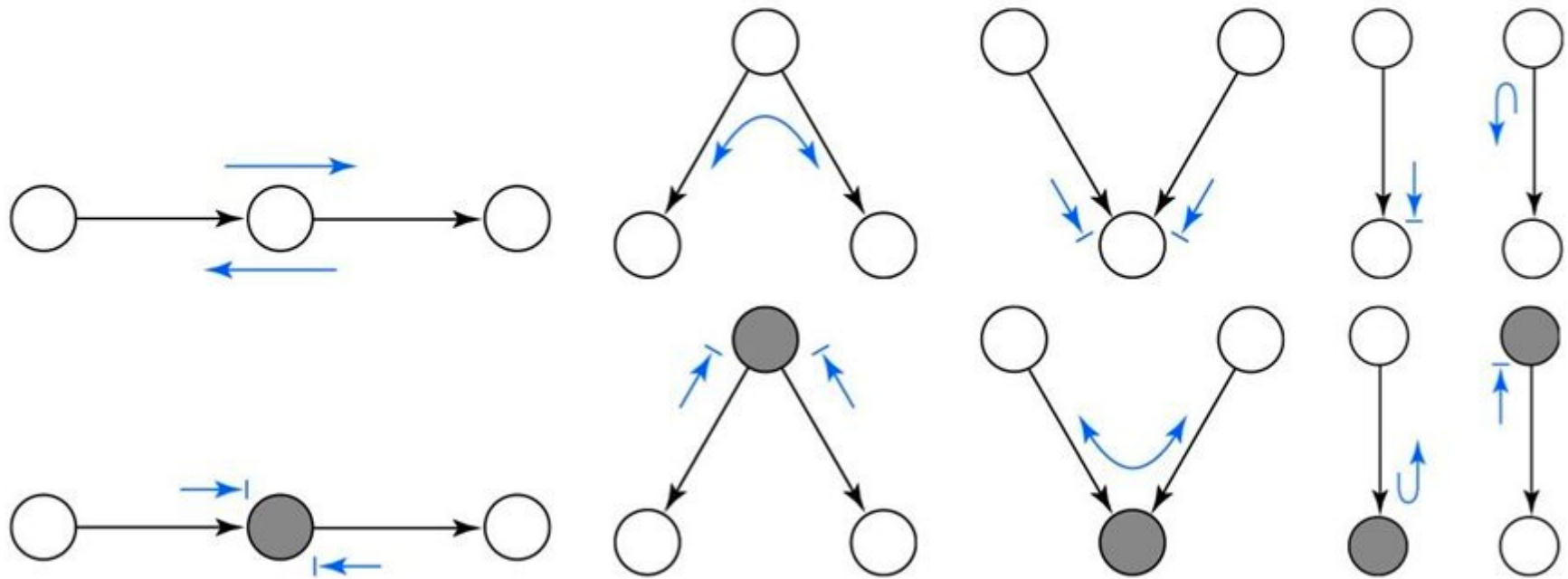

Please read [Jordan PGM Ch. 2.1]
to learn more about the Bayes Ball algorithm

Examples (revisited using Bayes-ball alg)

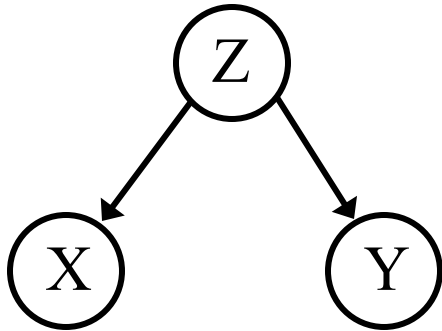
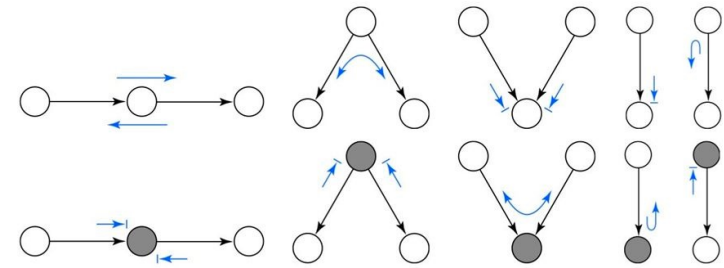

X – wet grass
 Y – rainbow
 Z – rain

$$P(X, Y) \neq P(X) P(Y)$$

$$P(X | Y, Z) = P(X | Z)$$

Are X and Y ind.? Are X and Y cond. ind. given...?

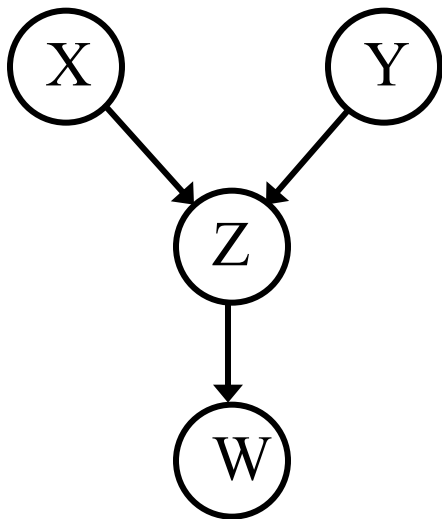

X – rain
 Y – sprinkler
 Z – wet grass
 W – worms

$$P(X, Y) = P(X) P(Y)$$

$$P(X | Y, Z) \neq P(X | Z)$$

$$P(X | Y, W) \neq P(X | W)$$

Examples (3 min work)

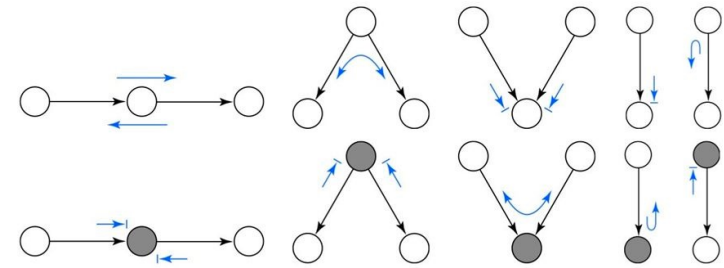

Are X and Y independent?

Are X and Y conditionally independent given Z?

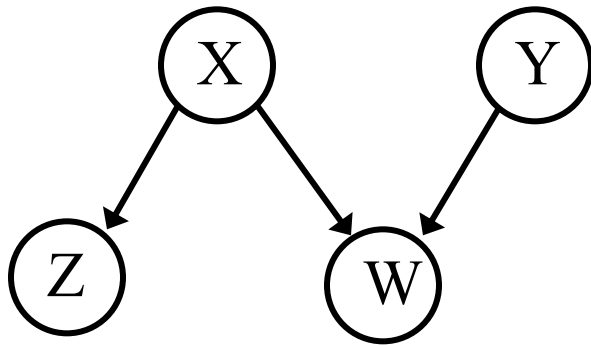

X – rain
 Y – sprinkler
 Z – rainbow
 W – wet grass

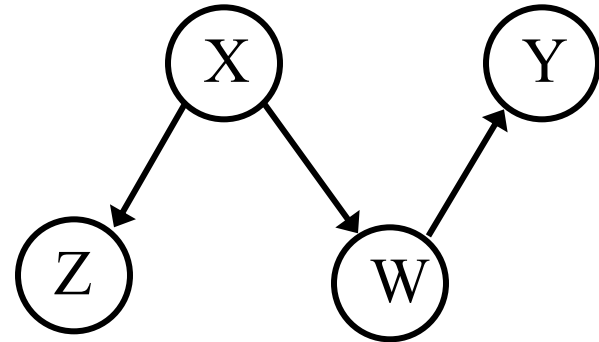

X – rain
 Y – sprinkler
 Z – rainbow
 W – wet grass

Conditional Independence

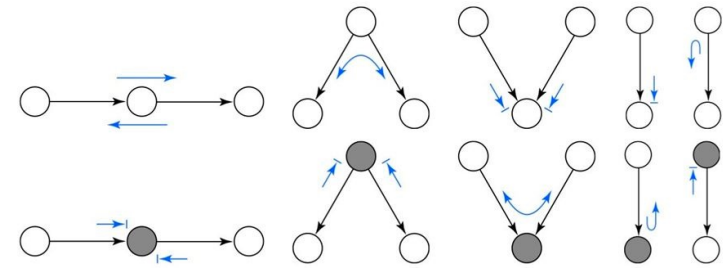

- Where are conditional independences here?

Radio and Ignition, given Battery?

Radio and Starts, given Ignition?

Gas and Radio, given Battery?

Gas and Radio, given Starts?

Gas and Radio, given nil?

Gas and Battery, given Moves?

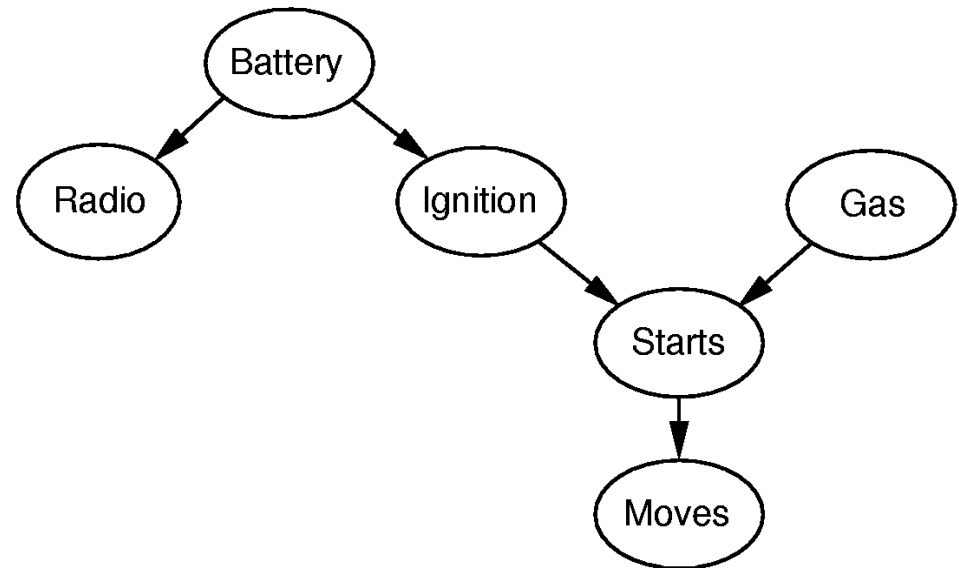

Quick checkpoint

- Reading conditional independences from the DAG itself.
- d-separation
 - Three canonical graphs: Chain, Fork, Collider
- Bayes ball algorithm for determining whether $\mathbf{X} \perp \mathbf{Z} \mid \mathbf{Y}$
 - Bounce the ball from any node in X by following the ten rules
 - If any ball reaches any node in Z, then return “False”
 - Otherwise, return “True”

An alternative view: Markov Blankets

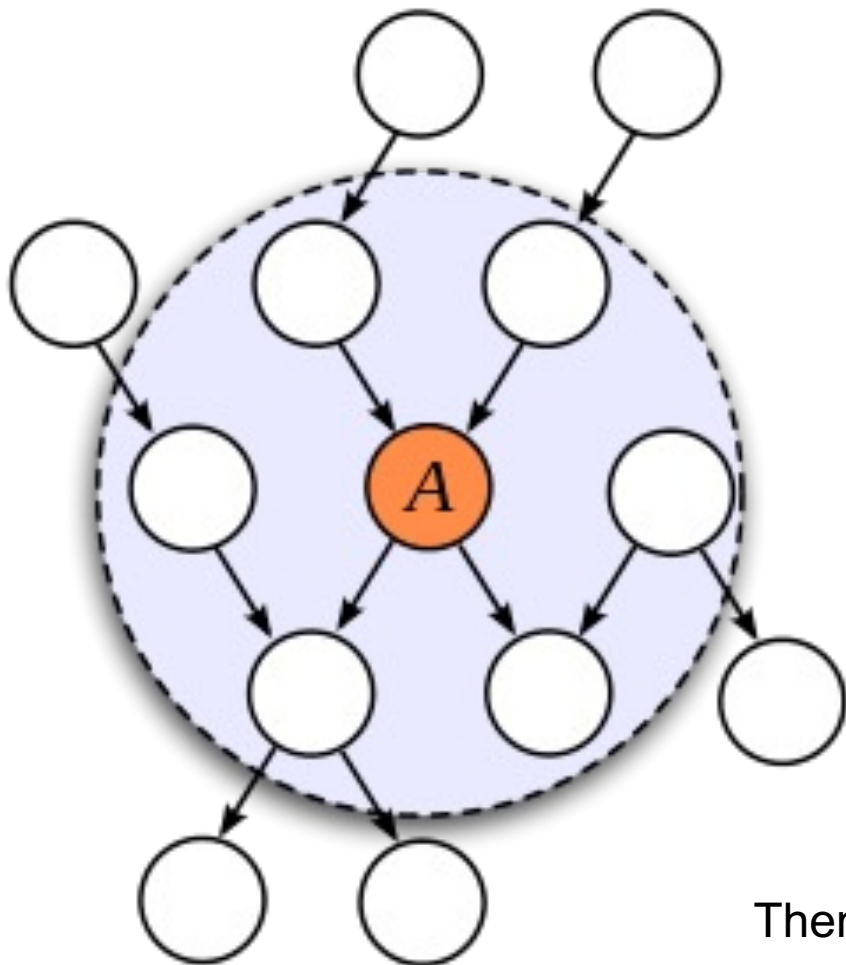

1. Parents
2. Children
3. Children's other parents

Then A is d-separated from everything else.

Example: Markov Blankets

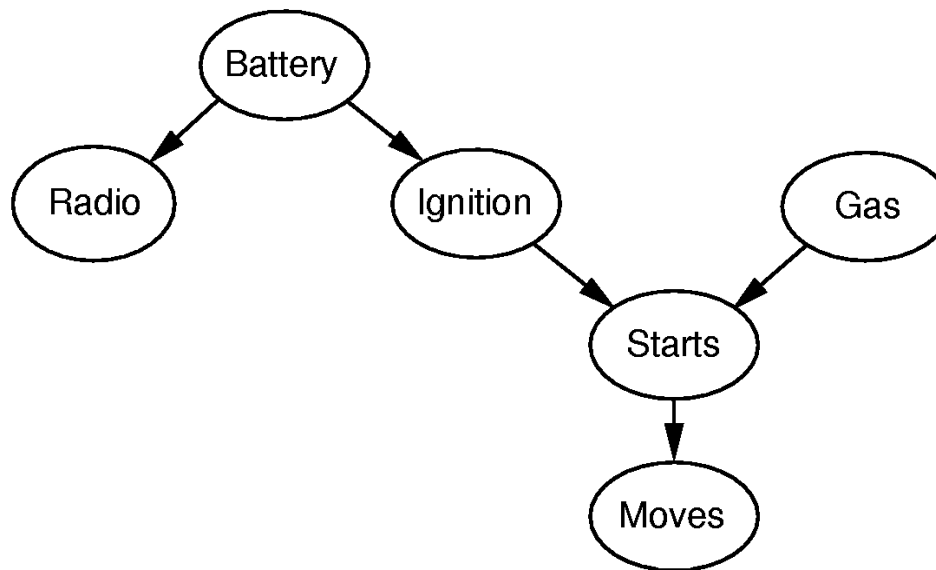

- Question: What is the Markov Blanket of ...
 - “Ignition”:
 - “Starts”:

Why are conditional independences important?

- Helps the developer (or the user) verify the graph structure
 - Are these variables really independent?
 - Do I need more/fewer edges in the graphical model?
- Statistical tests for (Conditional) Independence
 - Hilbert-Schmidt Independence Criterion (not covered)
- Hints on computational efficiencies
- Shows that you understand BNs...

Inference in Bayesian networks

- We've seen how to compute any probability from the Bayesian network
 - This is *probabilistic inference*
 - $P(\text{Query} \mid \text{Evidence})$
 - Since we know the joint probability, we can calculate anything via marginalization
 - $P(\text{Query}, \text{Evidence}) / P(\text{Evidence})$
- However, things are usually not as simple as this
 - Structure is large or very complicated
 - **Calculation by marginalization is often intractable**
 - Bayesian inference is NP hard in space and time!!
 - (Details in AIMA Ch 13.4)

Inference in Bayesian networks (cont.)

- So in all but the most simple BNs, probabilistic inference is not really done just by marginalization
- Instead, there are practical algorithms for doing approximate probabilistic inference
 - Recall a similar argument in surrogate losses in ML
- Markov Chain Monte Carlo, Message Passing / Loopy Belief Propagation
 - Active area of research!
- We won't cover these probabilistic inference algorithms though.... (Read AIMA Ch 13.5)

One more thing: Continuous Variables?

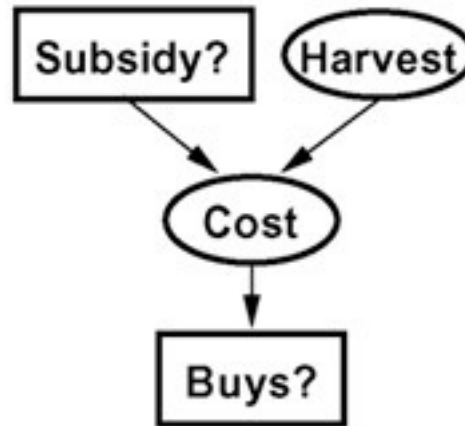

- Dimension check: What are the shapes of the CPTs?
- Discretize? Very large CPT..
- Usually, we parametrize the conditional distribution.
 - e.g., $P(\text{Cost} \mid \text{Harvest}) = \text{Poisson}(\theta^T \text{Harvest})$

Summary of today's lecture

- Encode knowledge / structures using a DAG
 - How to check conditional independence algebraically by the factorizations?
 - How to read off conditional independences from a DAG
 - d-separation, Bayes Ball algorithm, Markov Blanket
 - Remarks on BN inferences and continuous variables
- (More examples, e.g., Hidden Markov Models, see AIMA 13.3)**

Additional resources about PGM

- Recommended: Ch.2 Jordan book. AIMA Ch. 12-13.
- More readings (if you need to use PGMs in the future):
 - Koller's PGM book: <https://www.amazon.com/Probabilistic-Graphical-Models-Daphne-Koller/dp/B007YXTT12>
 - Probabilistic programming: <http://probabilistic-programming.org/wiki/Home>
- Software for PGMs and modeling and inference:
 - Stan: <https://mc-stan.org/>
 - JAGS: <http://mcmc-jags.sourceforge.net/>

Structure of the course

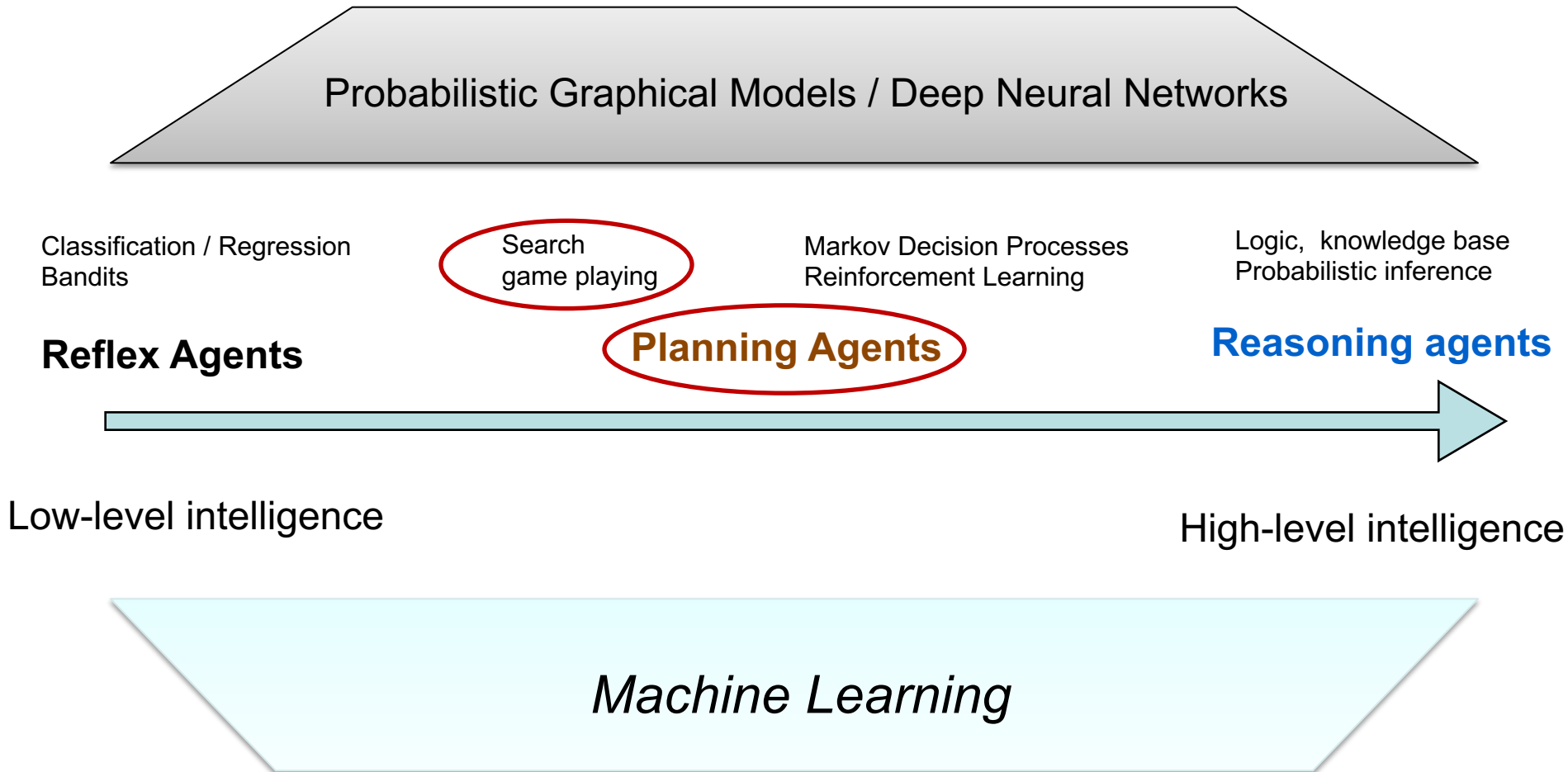

Reflex Agents vs. Planning agent

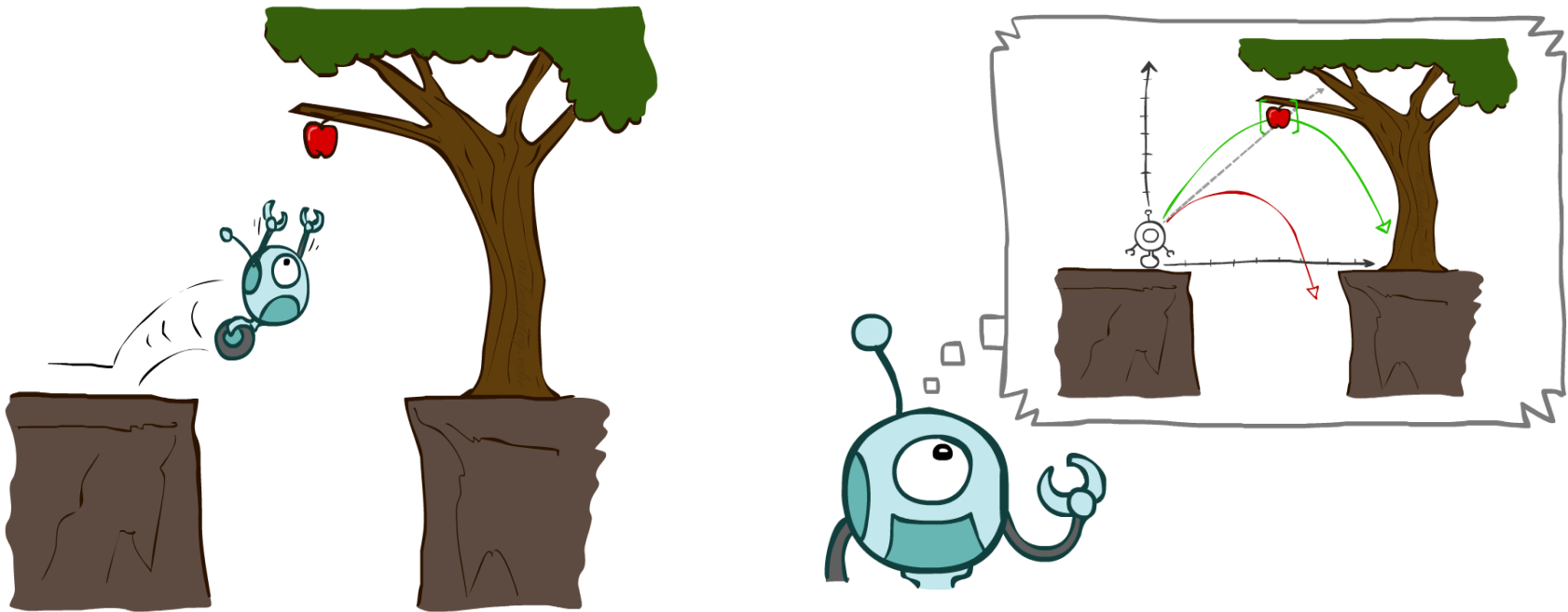

(illustration credit: Dan Klein)

- Reflex agents act based on immediate observation / memory; often optimizes immediate reward.
- Planning agent looks further into the future and “try out” different sequences of actions --- in its mind --- before taking an action; optimizes long-term reward.

Modeling-Learning-Inference Paradigm

	Modeling	Learning	Inference
Classifier agent (Spam filter)	Feature engineering Hypothesis class	Minimize Error rate	Prediction on new data points
Probabilistic Inference agent (Sherlock)	Joint distribution Draw edges in BN Conditional independences	Fitting the CPTs to Data	Marginalization (conceptually easy)
Search agents	State-Space- diagram	Environment given (learn edge weights)	Nontrivial search algorithms

Search sequence of lectures

- Today: Problem Solving by Search + Search algorithms
- Apr 27: Search algorithms
- May 2: Minimax search and game playing
- May 4: Finish “search” + Midterm review.

- Recommended readings on search:
 - AIMA Ch 3.1 – 3.6, Ch 5.1-5.4

Remaining time today

- Formulating problems as search problems
- Basic algorithms for search

Example: Romania

You're in Arad, Romania, and you need to get to Bucharest as quickly as possible to catch your flight.

- Formulate problem
 - States: Various cities
 - Operators: Drive between cities
- Formulate goal
 - Be in Bucharest before flight leaves
- Find solution
 - Actual sequence of cities from Arad to Bucharest
 - Minimize driving distance/time

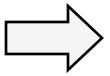

Romania (cont.)

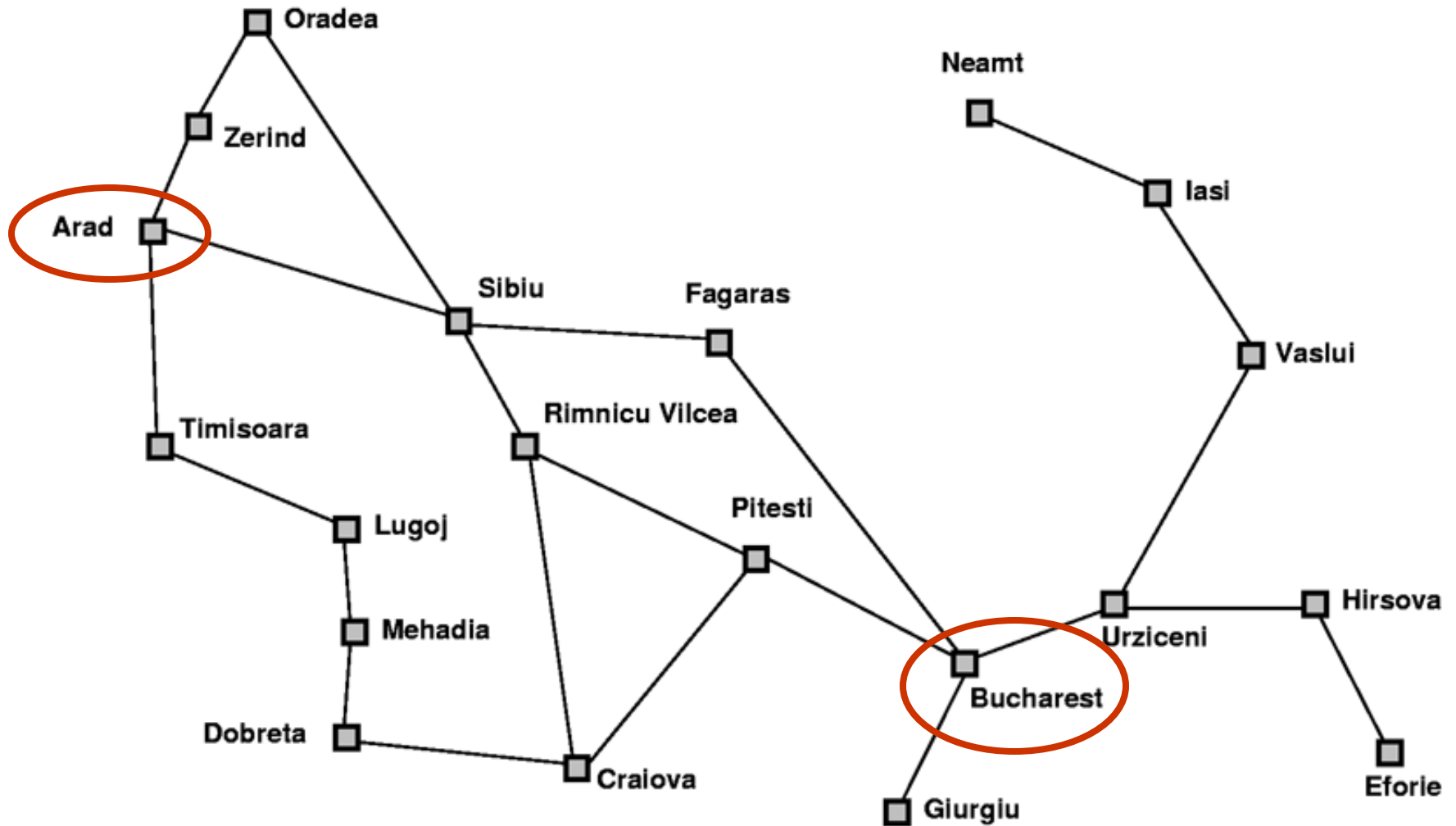

Romania (cont.)

Problem description $\langle \{S\}, S_0, \{S_G\}, \{O\}, \{g\} \rangle$

- $\{S\}$ – cities (c_i)
- S_0 – Arad
- S_G – Bucharest
 - $G(S)$ – Is the current state (S) Bucharest?
- $\{O\}$: $\{ c_i \rightarrow c_j, \text{ for some } i \text{ and } j \}$
- g_{ij}
 - Driving distance between c_i and c_j ?
 - Time to drive from c_i to c_j ?
 - 1?

Possible paths

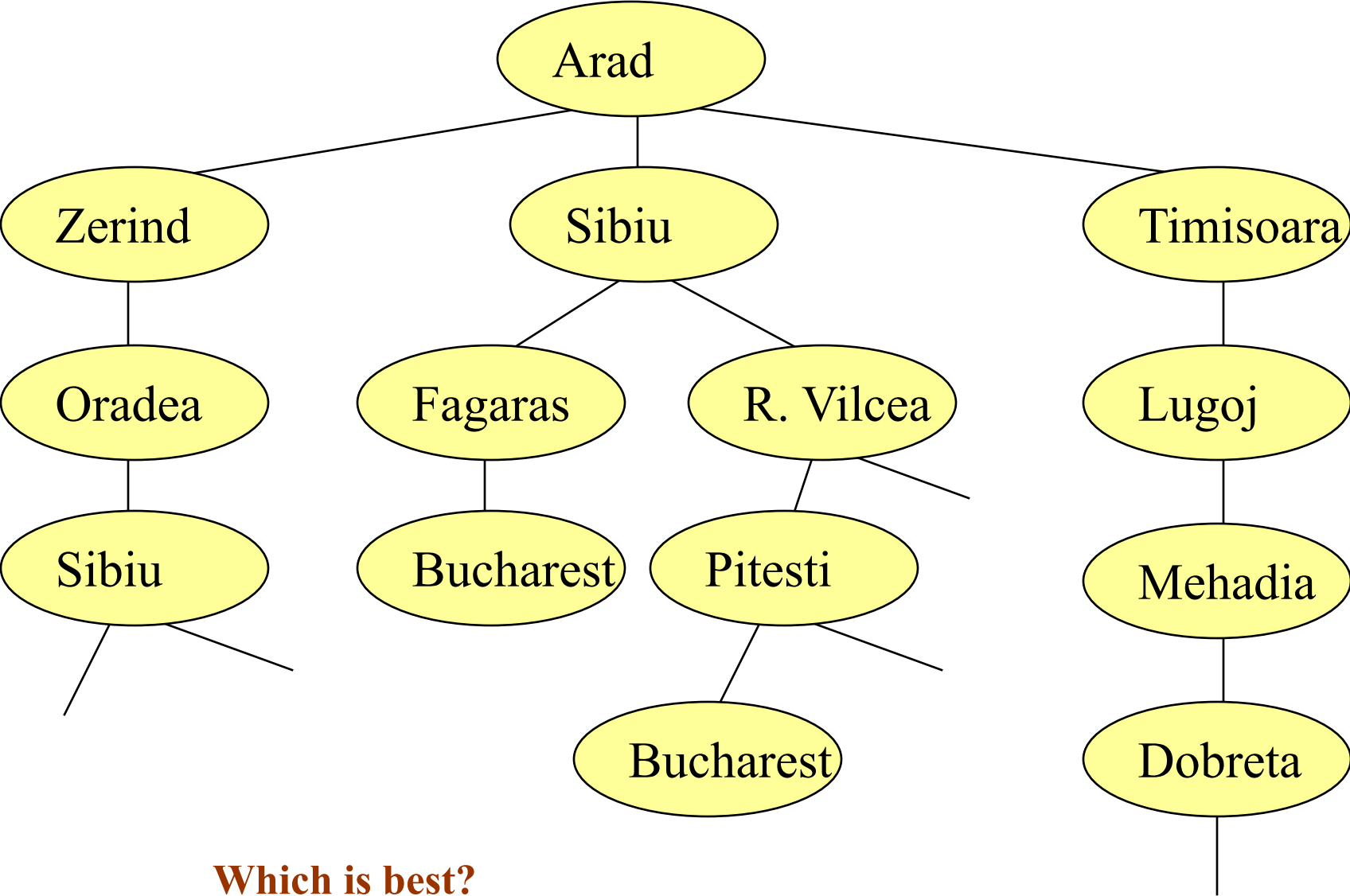

Which is best?



Should we consider cycles?

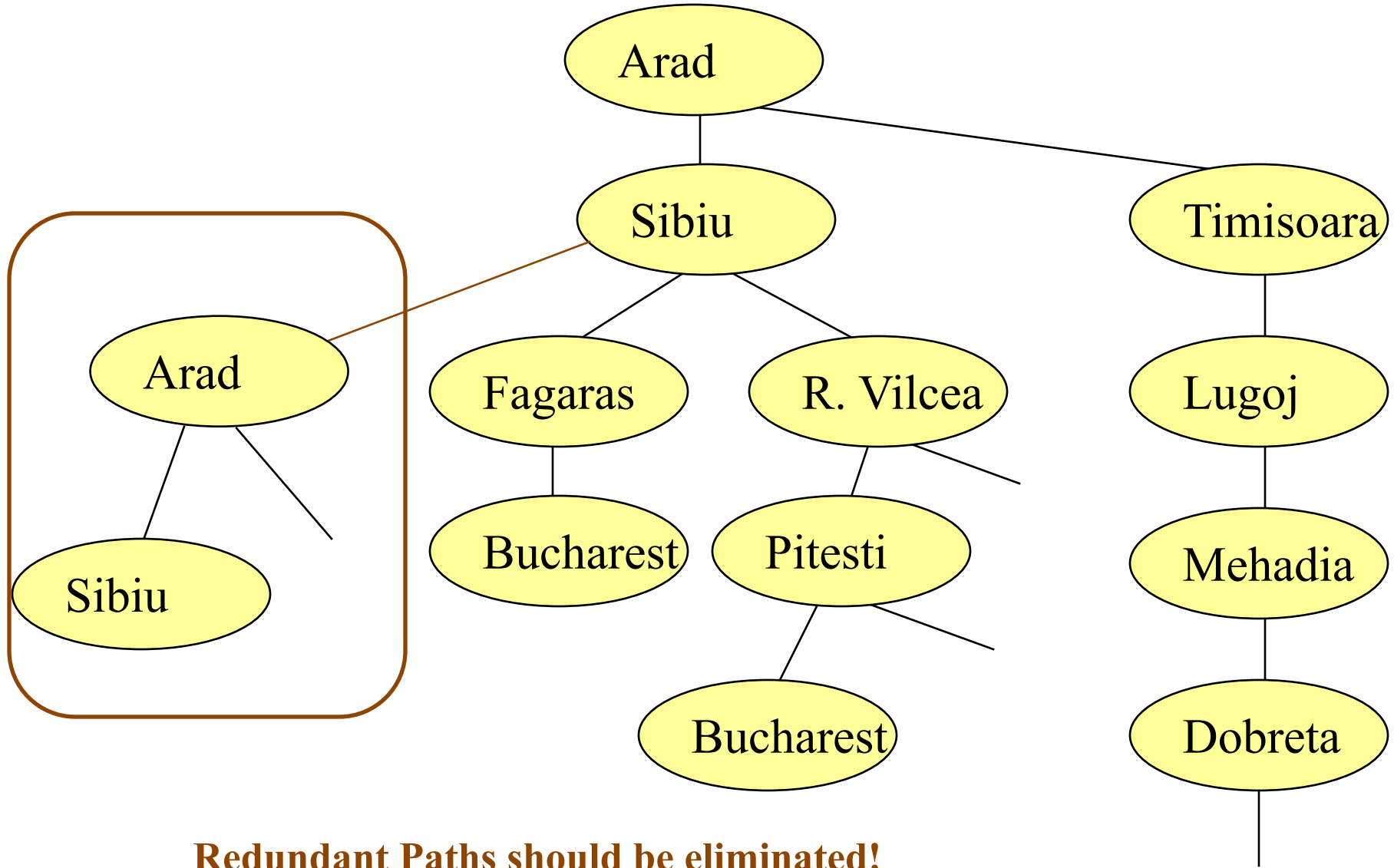

Redundant Paths should be eliminated!

Branching Factor and Depth

- If there are b possible choices at each state, then the **branching factor** is b
- If it takes d steps (state transitions) to get to the goal state, then it may be the case that $O(b^d)$ states have to be checked
 - $b = 3, d = 5 \rightarrow b^d = 243$
 - $b = 5, d = 10 \rightarrow b^d = 9,765,625$
 - $b = 8, d = 15 \rightarrow b^d = 35,184,372,088,832$
- Ouch.... Combinatorial explosion!

Abstraction

- The real world is highly complex!
 - The state space must be *abstracted* for problem-solving
 - Simplify and aggregate
 - Can't represent all the details
- Choosing a good abstraction
 - Keep only those relevant for the problem
 - Remove as much detail as possible *while retaining validity*

Problem Solving Agents

- Task: Find a sequence of actions that leads to desirable (goal) states
 - Must define *problem* and *solution*
- Finding a solution is typically a *search process* in the problem space
 - Solution = A path through the state space from the initial state to a goal state
 - Optimal search find the *least-cost* solution
- Search algorithm
 - Input: Problem statement (incl. goal)
 - Output: Sequence of actions that leads to a solution
- Formulate, search, execute (action)

Problem Formulation and Search

- Problem formulation
 - State-space description $\langle \{S\}, S_0, \{S_G\}, \{O\}, \{g\} \rangle$
 - **S**: Possible states
 - **S₀**: Initial state of the agent
 - **S_G**: Goal state(s)
 - Or equivalently, a goal test **G(S)**
 - **O**: Operators $O: \{S\} \Rightarrow \{S\}$
 - Describes the possible actions of the agent
 - **g**: Path cost function, assigns a cost to a path/action
- At any given time, which possible action **O_i** is best?
 - Depends on the goal, the path cost function, the future sequence of actions....
- Agent's strategy: Formulate, Search, and Execute
 - This is *offline* problem solving

State-Space Diagrams

- State-space description can be represented by a state-space diagram, which shows
 - States (incl. initial and goal)
 - Operators/actions (state transitions)
 - Path costs

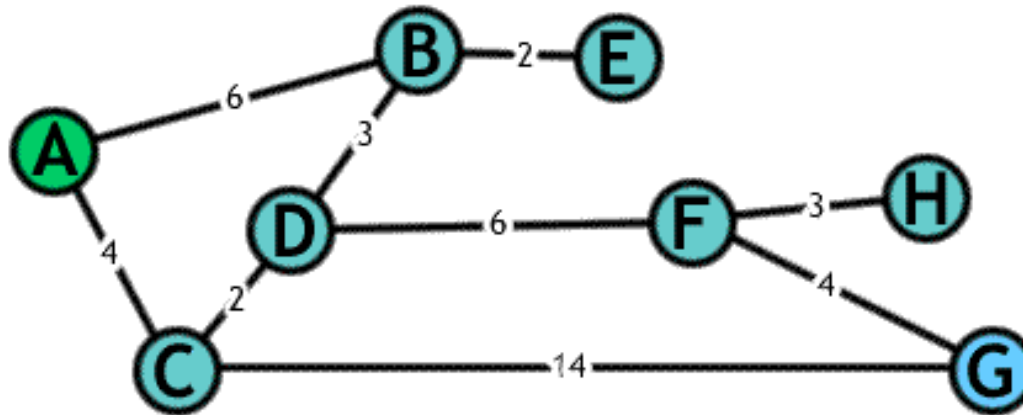

Typical assumptions

- Environment is observable
- Environment is static
- Environment is discrete
- Environment is deterministic

Example: The Vacuum World

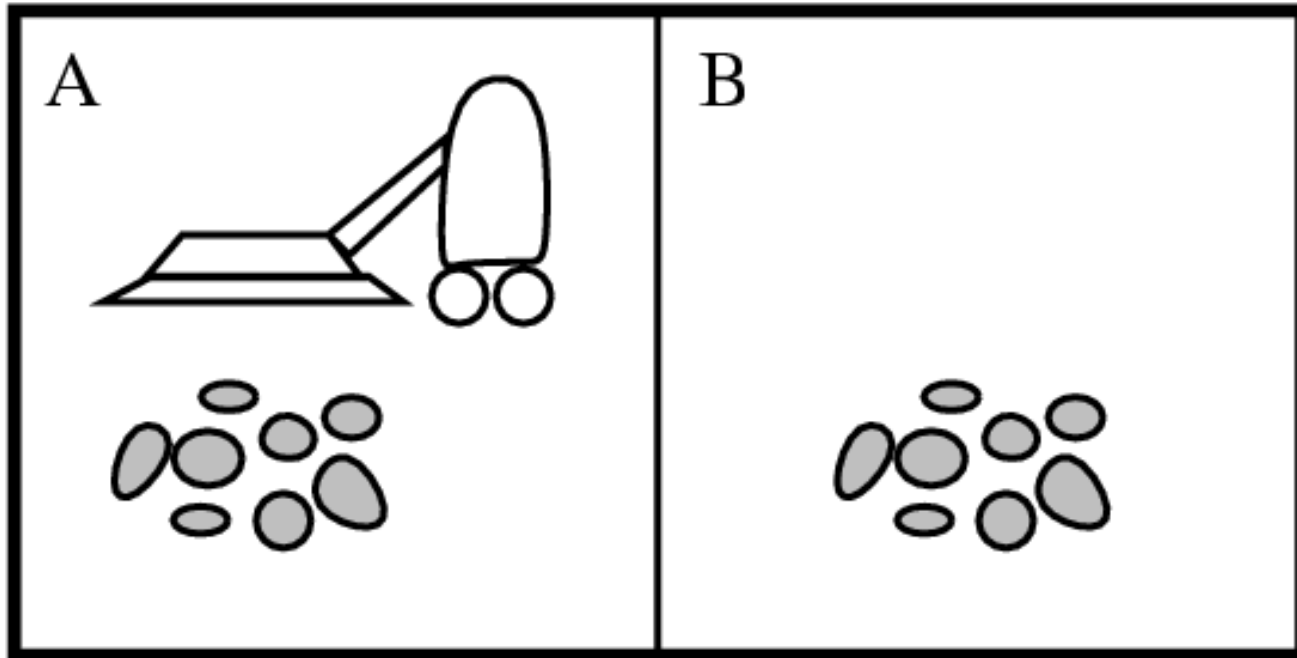

The Vacuum World

- Simplified world: 2 grids

States: Location of vacuum, dirt in grids

Operators: Move left, move right, suck dirt

Goal test: Grids free of dirt

Path cost: Each action costs 1

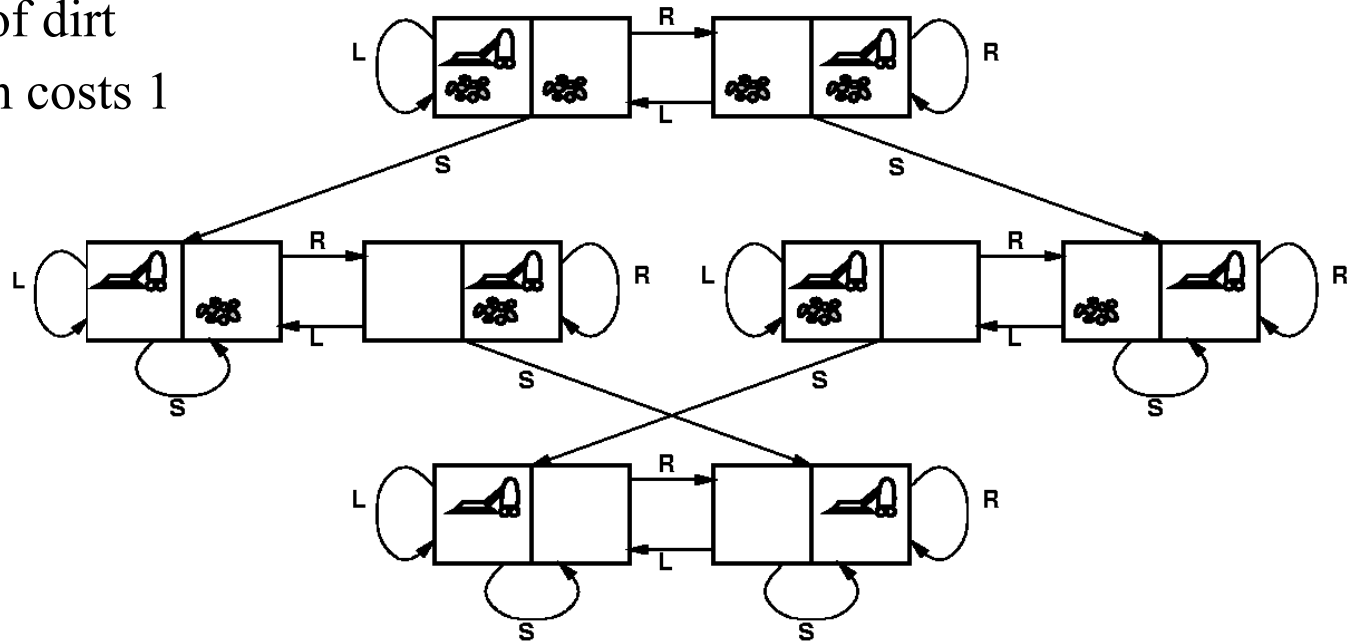

How many states
for n grids?

Example Problem: 8-Puzzle

5	4	
6	1	8
7	3	2

Start State

1	2	3
8		4
7	6	5

Goal State

States: Various configurations of the puzzle

Operators: Movements of the blank

Goal test: Goal configuration

Path cost: Each move costs 1

How many states
are there?

$$9! = 362,880$$

8-Puzzle is hard (by definition)!

- Optimal solution of the N-puzzle family of problems is NP-complete
 - Likely exponential increase in computation with N
 - Uninformed search will do very poorly
- Ditto for the Traveling Salesman Problem (TSP)
 - Start and end in Bucharest, visit every city at least once
 - Find the shortest tour
- Ditto for lots of interesting problems!

Example: Missionaries and Cannibals

(3 min discussion)

Problem: Three missionaries and three cannibals are on one side of a river, along with a boat that can hold one or two people. Find a way to get everyone to the other side, without ever leaving a group of missionaries in one place outnumbered by the cannibals in that place

- States, operators, goal test, path cost?

M&C (cont.)

- Initial state

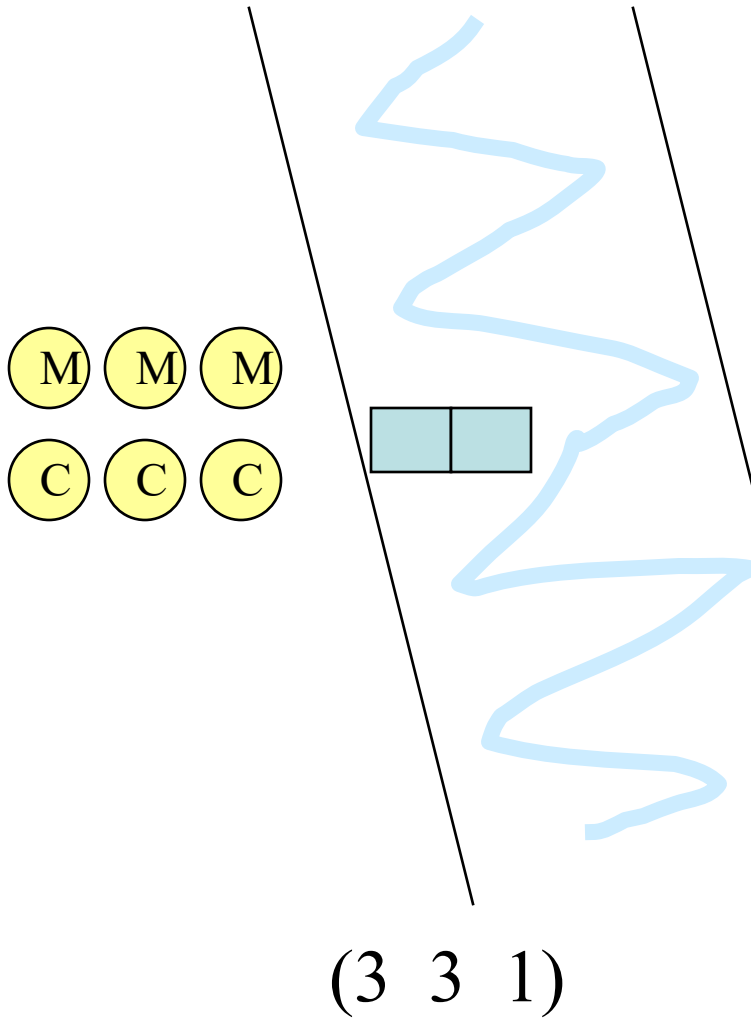

- Goal state

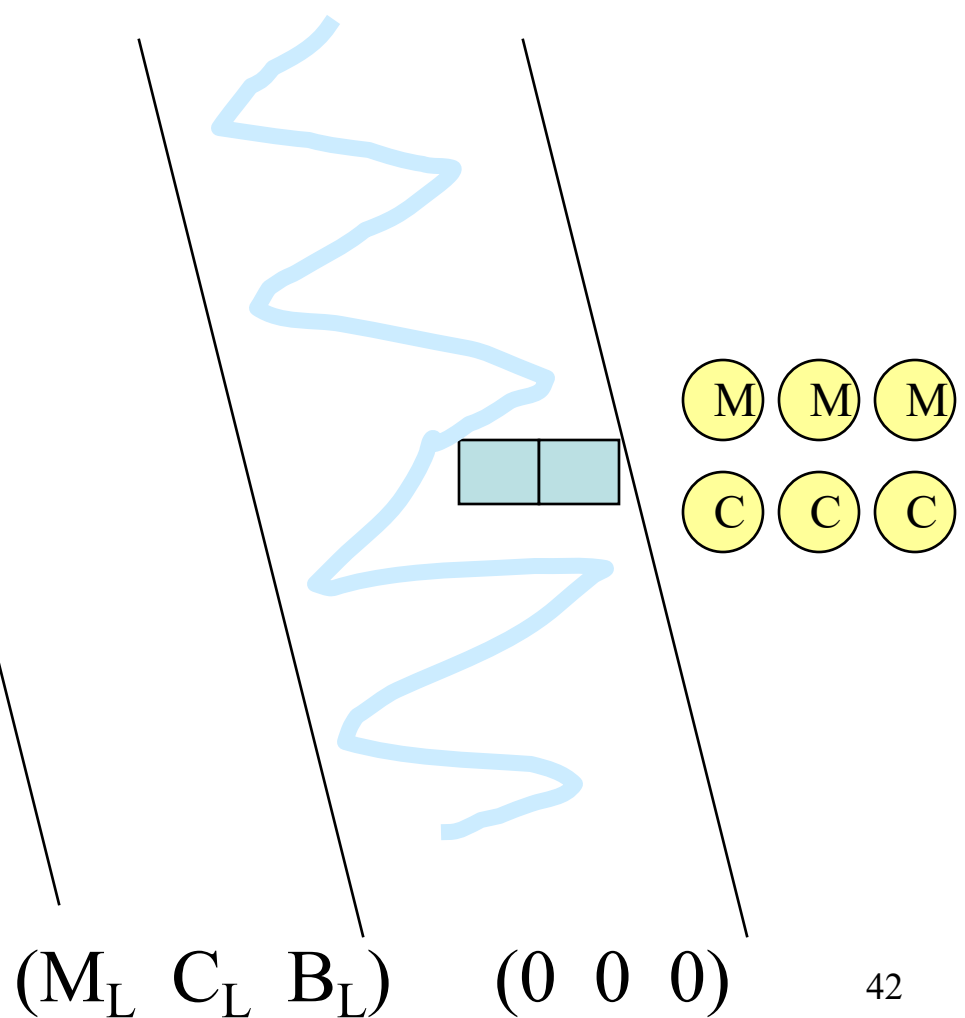

M&C (cont.)

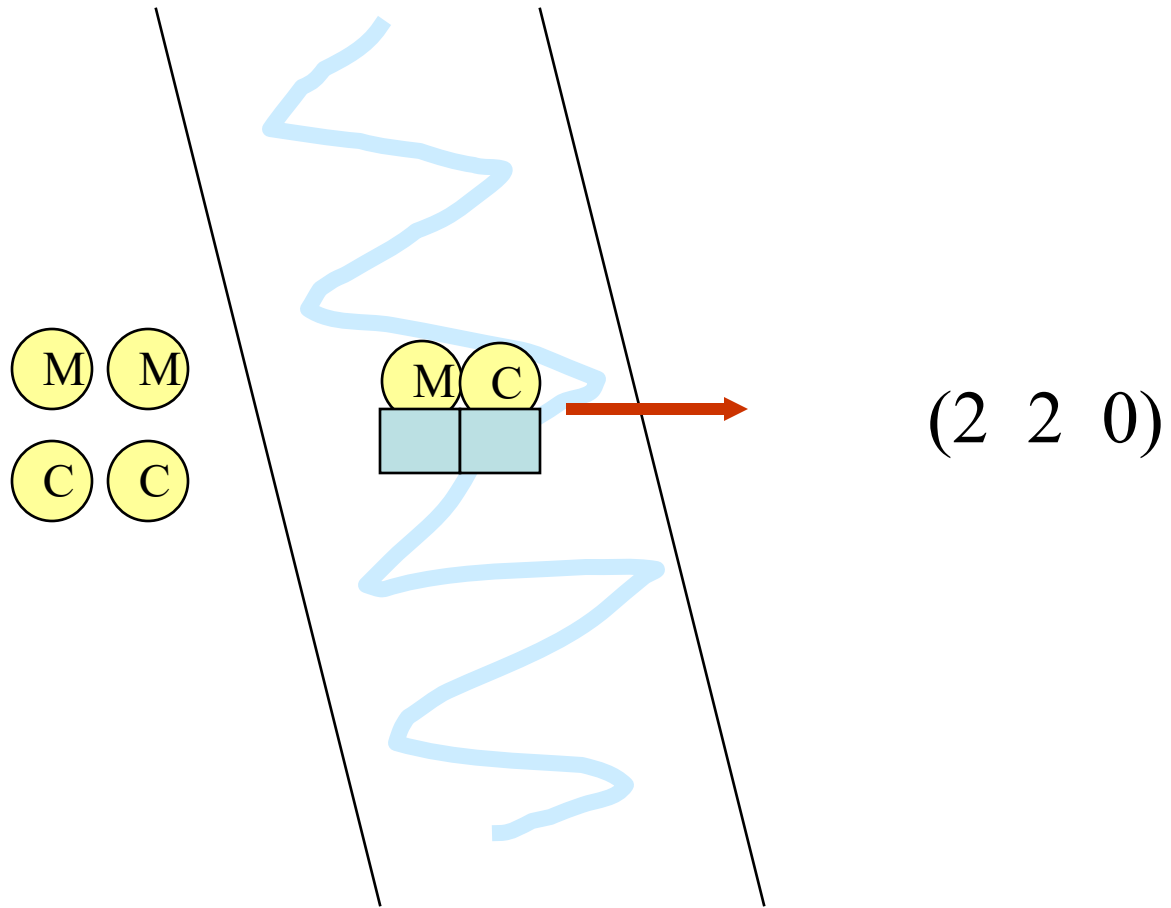

M&C (cont.)

- Problem description $\langle \{S\}, S_0, \{S_{G_j}\}, \{O_i\}, \{g_i\} \rangle$
- $\{S\} : \{ (\{0,1,2,3\} \{0,1,2,3\} \{0,1\}) \}$
- $S_0 : (3 \ 3 \ 1)$
- $S_G : (0 \ 0 \ 0)$
- $g = 1$
- $\{O\} : \{ (x \ y \ b) \rightarrow (x' \ y' \ b') \}$
- Safe state: $(x \ y \ b)$ is safe iff
 - $x > 0$ implies $x \geq y$ and
 $x < 3$ implies $y \geq x$
 - Can be restated as
 $(x = 1 \text{ or } x = 2)$ implies $(x = y)$

Operators:

$$(x \ y \ 1) \rightarrow (x-2 \ y \ 0)$$

$$(x \ y \ 1) \rightarrow (x-1 \ y-1 \ 0)$$

$$(x \ y \ 1) \rightarrow (x \ y-2 \ 0)$$

$$(x \ y \ 1) \rightarrow (x-1 \ y \ 0)$$

$$(x \ y \ 1) \rightarrow (x \ y-1 \ 0)$$

$$(x \ y \ 0) \rightarrow (x+2 \ y \ 1)$$

$$(x \ y \ 0) \rightarrow (x+1 \ y+1 \ 1)$$

$$(x \ y \ 0) \rightarrow (x \ y+2 \ 1)$$

$$(x \ y \ 0) \rightarrow (x+1 \ y \ 1)$$

$$(x \ y \ 0) \rightarrow (x \ y+1 \ 1)$$

M&C (cont.)

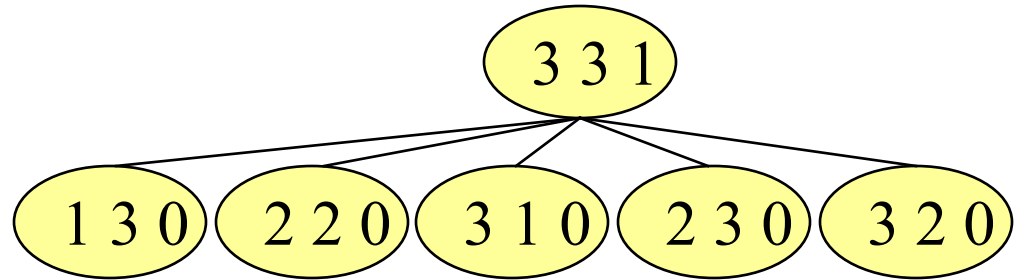

- 11 steps
- $5^{11} = 48$ million states to explore

One solution path:

(3 3 1)
(2 2 0)
(3 2 1)
(3 0 0)
(3 1 1)
(1 1 0)
(2 2 1)
(0 2 0)
(0 3 1)
(0 1 0)
(0 2 1)
(0 0 0)

Example: PACMAN

- The goal of a simplified PACMAN is to get to the pellet as quick as possible.
 - For a grid of size 30*30. Everything static.
 - What is a reasonable representation of the State, Operators, Goal test and Path cost?

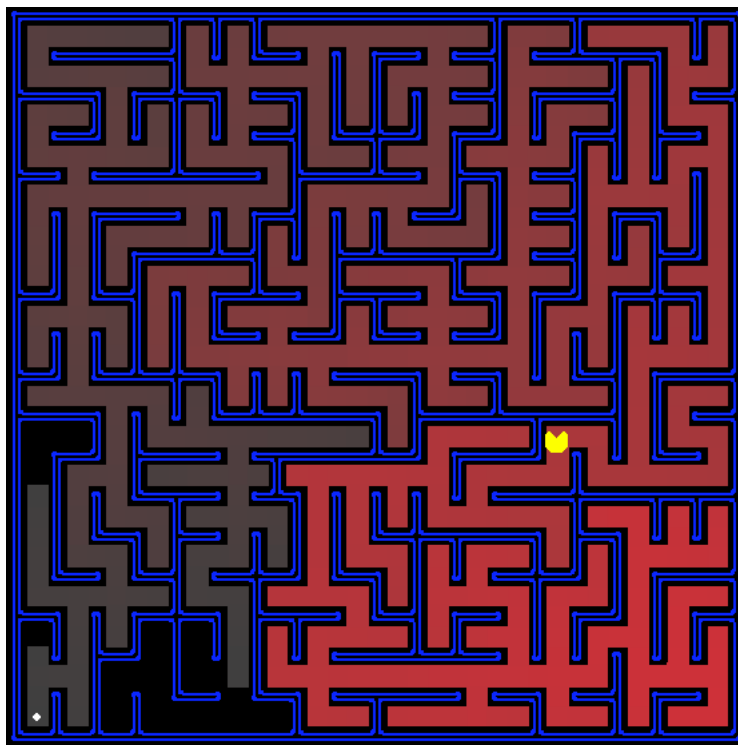

Example: PACMAN with static ghosts

- The goal is to eat all pellets as quickly as possible while staying alive. Eating the “Power pellet” will allow the pacman to eat the ghost.

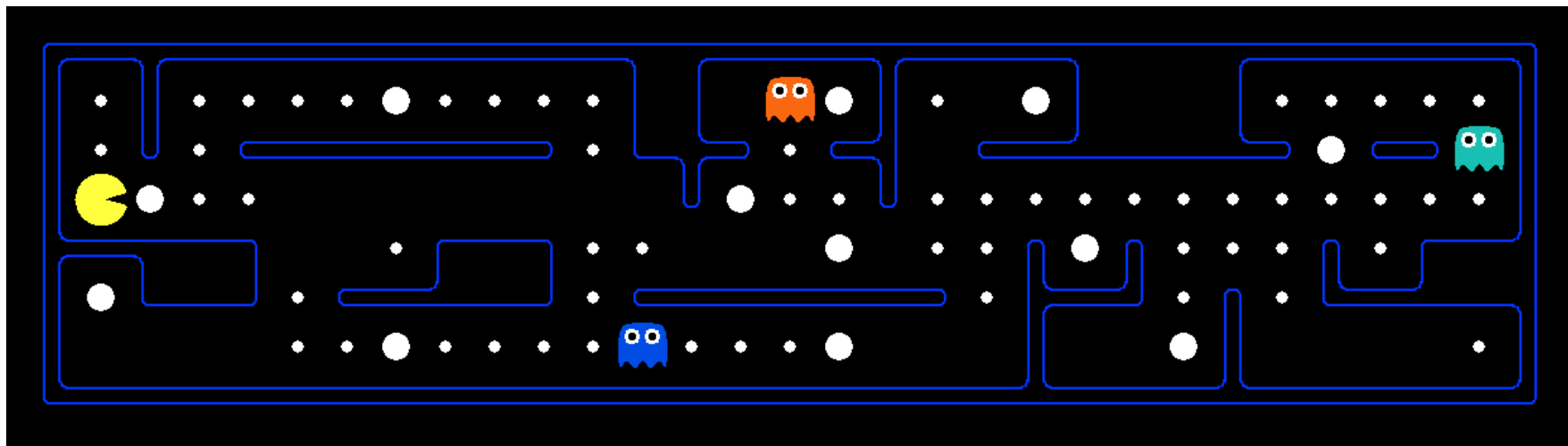

- Think about how to formulate this problem. We will revisit it in the next lecture.

Quick summary on problem formulation

- Formulate problems as a search problem
 - Decide your level of abstraction. State, Action, Goal, Cost.
 - Represented by a state-diagram
 - Required solution: A sequence of actions
 - Optimal solution: A sequence of actions with minimum cost.
- Caveats:
 - Might not be a finite graph
 - Might not have a solution
 - Often takes exponential time to find the optimal solution

Let's try solving it anyways!

- Do we need an exact optimal solution?

- Are problems in practice worst case?

Searching for Solutions

- Finding a solution is done by searching through the state space
 - While maintaining a set of partial solution sequences
- The *search strategy* determines which states should be expanded first
 - **Expand** a state = Applying the operators to the current state and thereby generating a new set of successor states
- Conceptually, the search process builds up a *search tree* that is superimposed over the state space
 - Root node of the tree \leftrightarrow Initial state
 - Leaves of the tree \leftrightarrow States to be expanded (or expanded to null)
 - At each step, the search algorithm chooses a leaf to expand

State Space vs. Search Tree

- The **state space** and the **search tree** are not the same thing!
 - A *state* represents a (possibly physical) configuration
 - A *search tree node* is a data structure which includes:
 - { parent, children, depth, path cost }
 - States do not have parents, children, depths, path costs
 - Number of states \neq number of nodes in the search tree

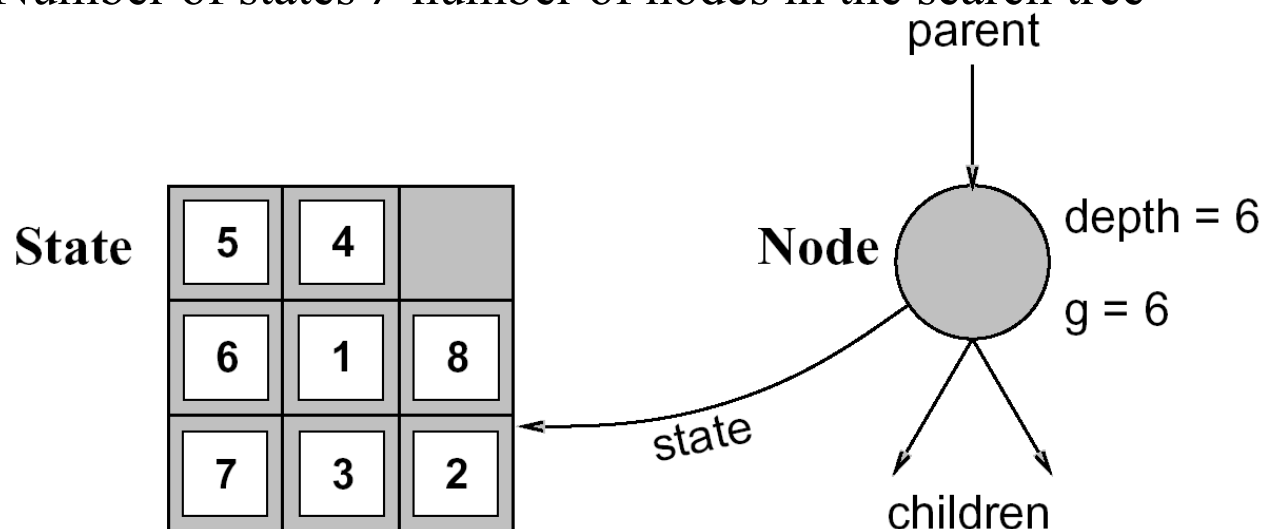

State Space vs. Search Tree (cont.)

State space: 8 states

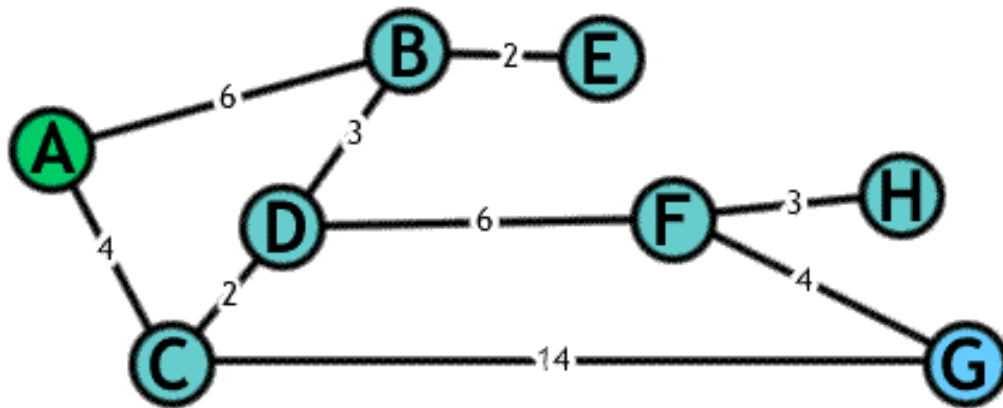

State Space vs. Search Tree (cont.)

Search tree (partially expanded)

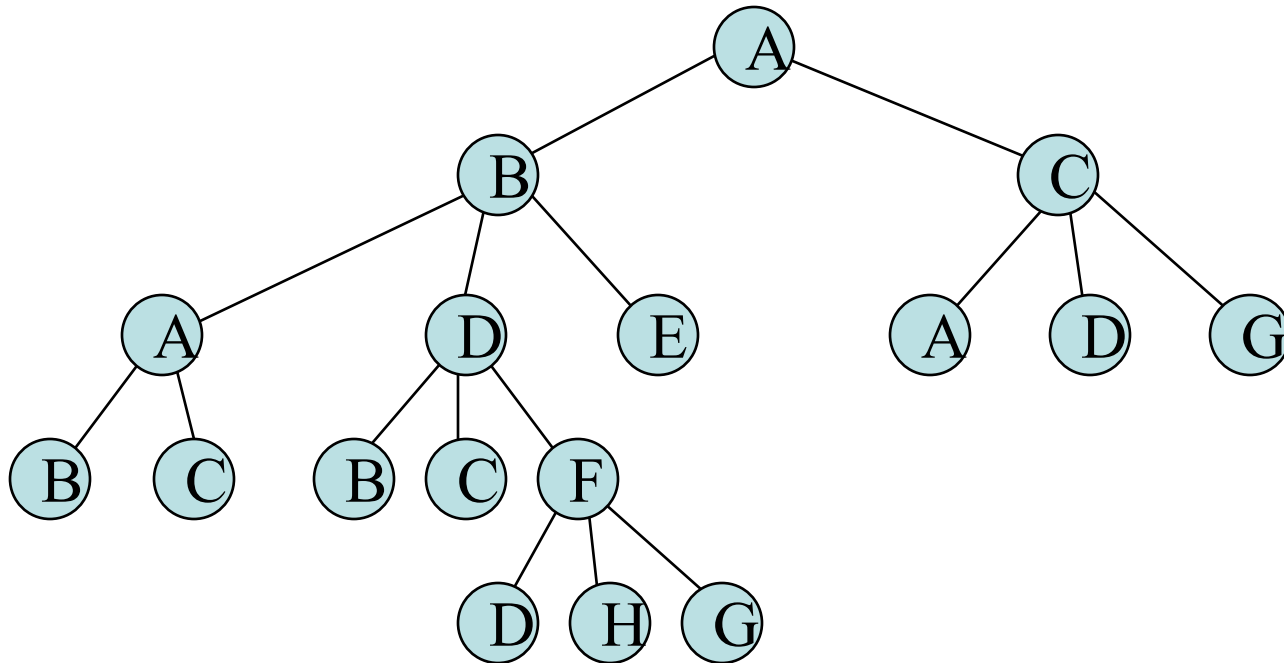

Search Strategies

- Uninformed (blind) search
 - Can only distinguish goal state from non-goal state
- Informed (heuristic) search
 - Can evaluate states

Uninformed (“Blind”) Search Strategies

- No information is available other than
 - The current state
 - Its parent (perhaps complete path from initial state)
 - Its operators (to produce successors)
 - The goal test
 - The current path cost (cost from start state to current state)
- Blind search strategies
 - Breadth-first search
 - Uniform cost search
 - Depth-first search
 - Depth-limited search
 - Iterative deepening search
 - Bidirectional search

General Search Algorithm (Version 1)

- Various strategies are merely variations of the following function:

```
function GENERAL-SEARCH(problem, strategy) returns a solution or failure  
  
initialize the search tree using the initial state of problem  
loop do  
  if there are no candidates for expansion then return failure  
  choose a leaf node for expansion according to strategy  
  if the node contains a goal state then return the corresponding solution  
  else expand the node and add the resulting nodes to the search tree  
end
```

(Called “Tree-Search” in the textbook)

General Search Algorithm (Version 2)

- Uses a queue (a list) and a **queuing function** to implement a *search strategy*
 - **Queuing-Fn**(*queue, elements*) inserts a set of elements into the queue and determines the order of node expansion

function GENERAL-SEARCH(*problem*, QUEUING-FN) **returns** a solution or failure

nodes ← MAKE-QUEUE(MAKE-NODE(INITIAL-STATE[*problem*]))

loop do

if *nodes* is empty **then return** failure

node ← REMOVE-FRONT(*nodes*)

if GOAL-TEST[*problem*] applied to STATE(*node*) succeeds **then return** *node*

nodes ← QUEUING-FN(*nodes*, EXPAND(*node*, OPERATORS[*problem*]))

end

“**Nodes**” is also known as a “**frontier**” --- the set of states we haven’t yet explored/expanded.

“**EXPAND**” is known as the “**successor function**” --- the set of all states that you could expand on.

How do we evaluate a search algorithm?

- Primary criteria to evaluate search strategies
 - **Completeness**
 - Is it guaranteed to find a solution (if one exists)?
 - **Optimality** **Note that this is not saying it's space/time complexity is optimal.*
 - Does it find the “best” solution (if there are more than one)?
 - **Time complexity**
 - Number of nodes generated/expanded
 - (How long does it take to find a solution?)
 - **Space complexity**
 - How much memory does it require?
- Some performance measures
 - Best case
 - Worst case 
 - Average case
 - Real-world case

How do we evaluate a search algorithm?

- Complexity analysis and $O(\)$ notation (see Appendix A)
 - b = Maximum branching factor of the search tree
 - d = Depth of an optimal solution (may be more than one)
 - m = maximum depth of the search tree (may be infinite)
- Examples
 - $O(b^3 d^2)$ – polynomial time
 - $O(b^d)$ – exponential time

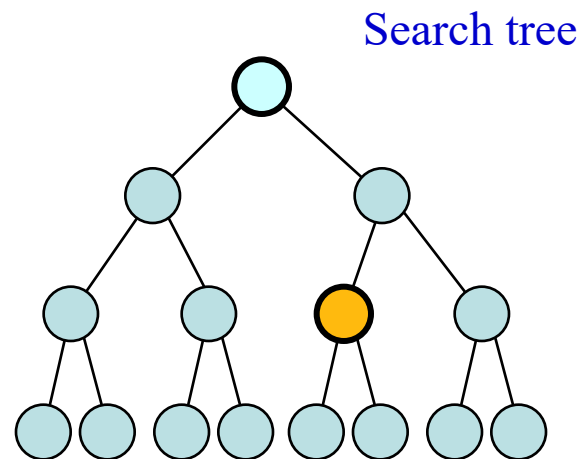

For chess, $b_{ave} = 35$

$b = 2, d = 2, m = 3$

Breadth-First Search

- All nodes at depth d in the search tree are expanded before any nodes at depth $d+1$
 - First consider all paths of length N , then all paths of length $N+1$, etc.
- Doesn't consider path cost – finds the solution with the shortest path
- Uses FIFO queue

```
function BREADTH-FIRST-SEARCH(problem) returns a solution or failure  
return GENERAL-SEARCH(problem, ENQUEUE-AT-END)
```

Example

State space graph

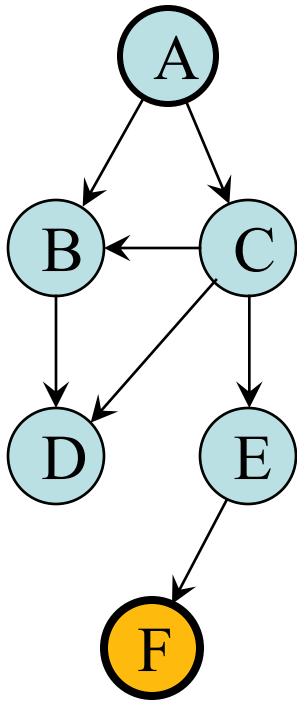

Search tree

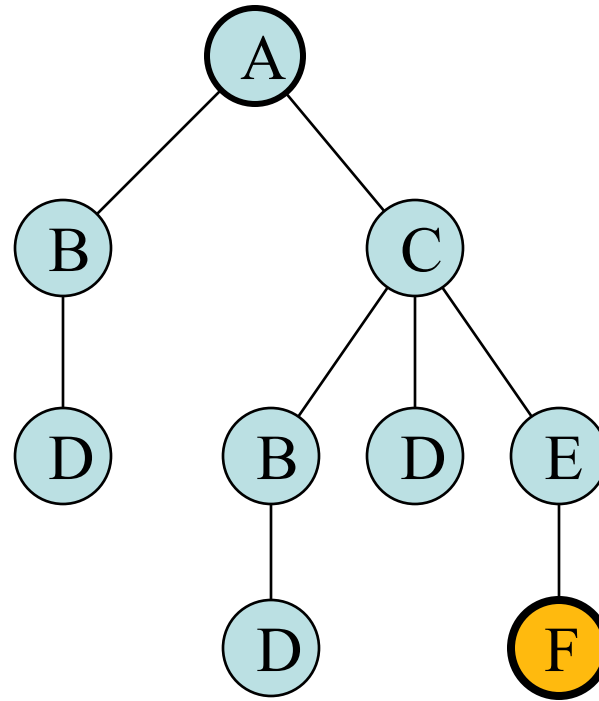

Queue

- (A)
- (B C)
- (C D)
- (D B D E)
- (B D E)
- (D E D)
- (E D)
- (D F)
- (F)
- ()

Breadth-First Search

- Complete? Yes
- Optimal? If shallowest goal is optimal
- Time complexity? Exponential: $O(b^{d+1})$
- Space complexity? Exponential: $O(b^{d+1})$

In practice, the memory requirements are typically worse than the time requirements

b = branching factor (require finite b)
d = depth of shallowest solution

Depth-First Search

- Always expands one of the nodes at the deepest level of the tree
 - Low memory requirements
 - Problem: depth could be infinite
- Uses a stack (LIFO)

```
function DEPTH-FIRST-SEARCH(problem) returns a solution or failure  
return GENERAL-SEARCH(problem, ENQUEUE-AT-FRONT)
```

Example

State space graph

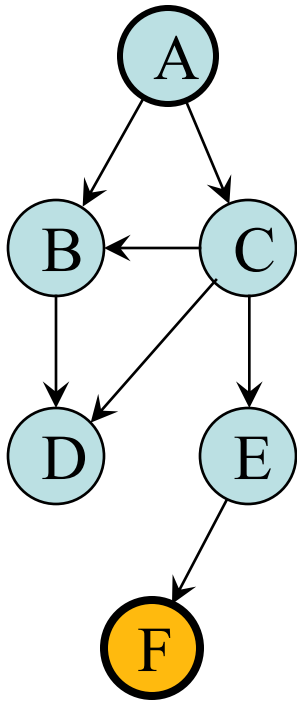

Search tree

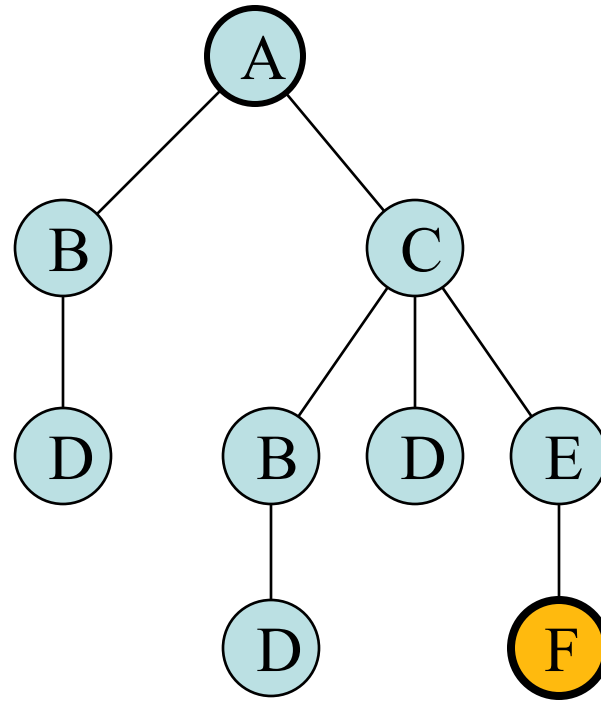

Queue

- (A)
- (B C)
- (D C)
- (C)
- (B D E)
- (D D E)
- (D E)
- (E)
- (F)

Depth-First Search

- Complete? No
- Optimal? No
- Time complexity? Exponential: $O(b^m)$
- Space complexity? Polynomial: $O(bm)$

m = maximum depth of the search tree
(may be infinite)

What is the difference between the BFS / DFS that you learned from the algorithm / data structure course?

- Nothing, except:
 - Now you are applying them to solve an AI problem
 - The graph can be infinitely large
 - The graph does not need to be known ahead of time (you only need local information: Goal-state checker, Successor function)

Next lecture

- Informed search (aka Heuristic search)
- Start game solving / minimax search
- You should:
 - Read Chapter 3 of AIMA textbook