

Introduction to Programming with Python

Programming basics

- **code** or **source code**: The sequence of instructions in a program.
- **syntax**: The set of legal structures and commands that can be used in a particular programming language.
- **output**: The messages printed to the user by a program.
- **console**: The text box onto which output is printed.
 - Some source code editors pop up the console as an external window, and others contain their own console window.

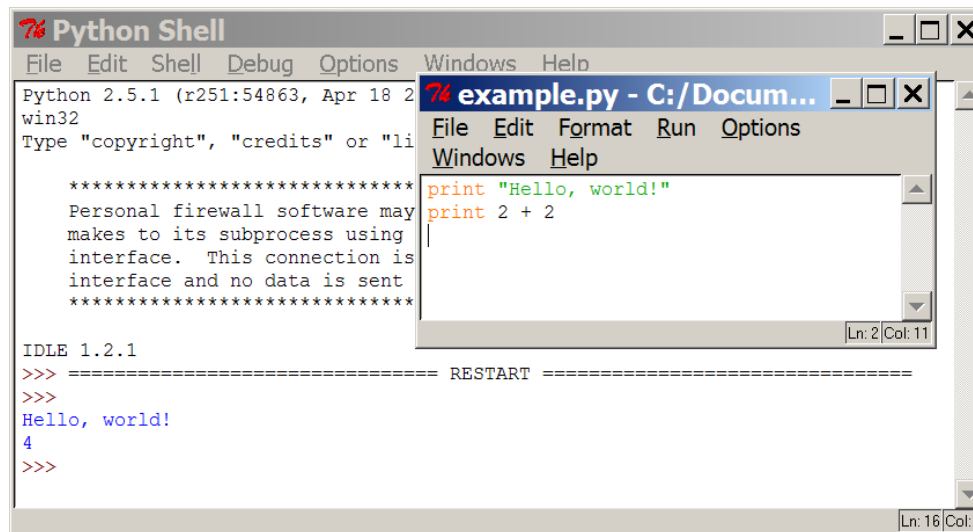

The image shows two overlapping windows. The background window is titled 'Python Shell' and contains the following text:

```
Python 2.5.1 (r251:54863, Apr 18 2006) on win32
Type "copyright", "credits" or "license()" for more
>>>
*****
Personal firewall software may
makes to its subprocess using
interface. This connection is
interface and no data is sent
*****
IDLE 1.2.1
>>> ===== RESTART =====
>>>
Hello, world!
4
>>>
```

The foreground window is titled 'example.py - C:/Docum...' and contains the following code:

```
print "Hello, world!"
print 2 + 2
```

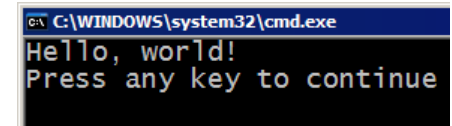

The image shows a command prompt window titled 'C:\WINDOWS\system32\cmd.exe' with the following output:

```
Hello, world!
Press any key to continue
```

Compiling and interpreting

- Many languages require you to *compile* (translate) your program into a form that the machine understands.

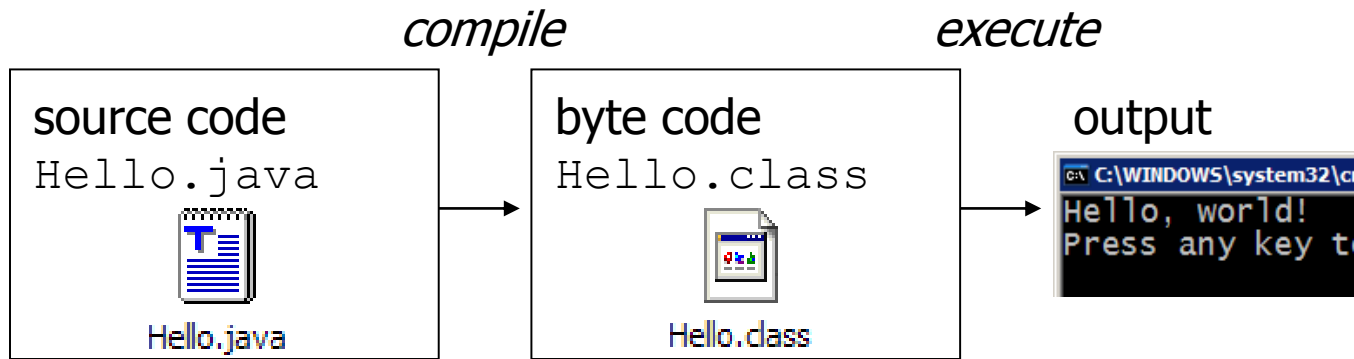

- Python is instead directly *interpreted* into machine instructions.

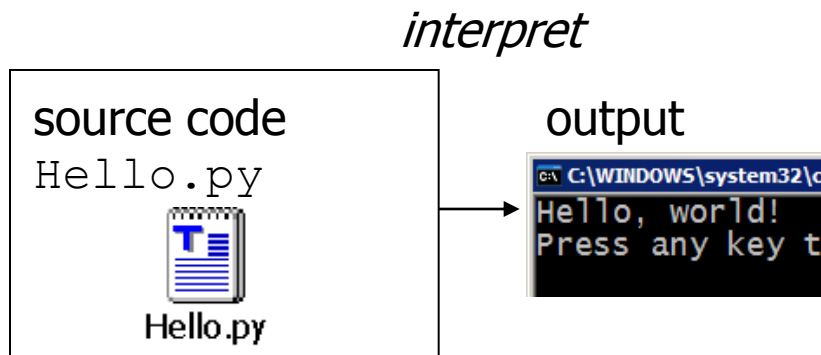

The Python Interpreter

- Python is an interpreted language
- The interpreter provides an interactive environment to play with the language
- Results of expressions are printed on the screen

```
>>> 3 + 7
10
>>> 3 < 15
True
>>> 'print me'
'print me'
>>> print 'print me'
print me
>>>
```

Expressions

- **expression:** A data value or set of operations to compute a value.

Examples: $1 + 4 * 3$
 42

- Arithmetic operators we will use:

$+$	$-$	$*$	$/$	addition, subtraction/negation, multiplication, division
$\%$				modulus, a.k.a. remainder
$**$				exponentiation

- **precedence:** Order in which operations are computed.

- $*$ / $\%$ $**$ have a higher precedence than $+$ $-$

$1 + 3 * 4$ is 13

- Parentheses can be used to force a certain order of evaluation.

$(1 + 3) * 4$ is 16

Integer division

- When we divide integers with $/$, the quotient is also an integer.

$$\begin{array}{r} 3 \\ 4 \overline{) 14} \\ \underline{12} \\ 2 \end{array}$$

$$\begin{array}{r} 52 \\ 27 \overline{) 1425} \\ \underline{135} \\ 75 \\ \underline{54} \\ 21 \end{array}$$

- More examples:

- $35 / 5$ is 7
- $84 / 10$ is 8
- $156 / 100$ is 1

- The $\%$ operator computes the remainder from a division of integers.

$$\begin{array}{r} 3 \\ 4 \overline{) 14} \\ \underline{12} \\ 2 \end{array}$$

$$\begin{array}{r} 43 \\ 5 \overline{) 218} \\ \underline{20} \\ 18 \\ \underline{15} \\ 3 \end{array}$$

Real numbers

- Python can also manipulate real numbers.
 - Examples: 6.022 -15.9997 42.0 2.143e17
- The operators + - * / % ** () all work for real numbers.
 - The / produces an exact answer: 15.0 / 2.0 is 7.5
 - The same rules of precedence also apply to real numbers:
Evaluate () before * / % before + -
- When integers and reals are mixed, the result is a real number.
 - Example: 1 / 2.0 is 0.5
 - The conversion occurs on a per-operator basis.

$$\begin{array}{r} 7 / 3 * 1.2 + 3 / 2 \\ \underline{2} * 1.2 + 3 / 2 \\ 2.4 + \underline{3 / 2} \\ 2.4 + \underline{1} \\ \underline{3.4} \end{array}$$

Math commands

- Python has useful commands (or called functions) for performing calculations.

Command name	Description
<code>abs(<i>value</i>)</code>	absolute value
<code>ceil(<i>value</i>)</code>	rounds up
<code>cos(<i>value</i>)</code>	cosine, in radians
<code>floor(<i>value</i>)</code>	rounds down
<code>log(<i>value</i>)</code>	logarithm, base <i>e</i>
<code>log10(<i>value</i>)</code>	logarithm, base 10
<code>max(<i>value1</i>, <i>value2</i>)</code>	larger of two values
<code>min(<i>value1</i>, <i>value2</i>)</code>	smaller of two values
<code>round(<i>value</i>)</code>	nearest whole number
<code>sin(<i>value</i>)</code>	sine, in radians
<code>sqrt(<i>value</i>)</code>	square root

Constant	Description
<code>e</code>	2.7182818...
<code>pi</code>	3.1415926...

- To use many of these commands, you must write the following at the top of your Python program:

```
from math import *
```

Numbers: Floating Point

- `int(x)` converts `x` to an integer
- `float(x)` converts `x` to a floating point
- The interpreter shows a lot of digits

```
>>> 1.23232
1.232320000000000001
>>> print 1.23232
1.23232
>>> 1.3E7
13000000.0
>>> int(2.0)
2
>>> float(2)
2.0
```

Variables

- **variable:** A named piece of memory that can store a value.

- Usage:

- Compute an expression's result,
- store that result into a variable,
- and use that variable later in the program.



- **assignment statement:** Stores a value into a variable.

- Syntax:

name = value

- Examples:

`x = 5`

`gpa = 3.14`

x

5

gpa

3.14

- A variable that has been given a value can be used in expressions.

`x + 4` is 9

- **Exercise:** Evaluate the quadratic equation for a given a , b , and c .

Example

```
>>> x = 7
```

```
>>> x
```

```
7
```

```
>>> x+7
```

```
14
```

```
>>> x = 'hello'
```

```
>>> x
```

```
'hello'
```

```
>>>
```

print

- `print` : Produces text output on the console.

- Syntax:

```
print "Message"
```

```
print Expression
```

- Prints the given text message or expression value on the console, and moves the cursor down to the next line.

```
print Item1, Item2, ..., ItemN
```

- Prints several messages and/or expressions on the same line.

- Examples:

```
print "Hello, world!"
```

```
age = 45
```

```
print "You have", 65 - age, "years until retirement"
```

Output:

```
Hello, world!
```

```
You have 20 years until retirement
```

Example: print Statement

- Elements separated by commas print with a space between them
- A comma at the end of the statement (`print 'hello',`) will not print a newline character

```
>>> print 'hello'
```

```
hello
```

```
>>> print 'hello', 'there'
```

```
hello there
```

input

- `input` : Reads a number from user input.
 - You can assign (store) the result of `input` into a variable.
 - Example:

```
age = input("How old are you? ")
print "Your age is", age
print "You have", 65 - age, "years until retirement"
```

Output:

```
How old are you? 53
Your age is 53
You have 12 years until retirement
```

- **Exercise:** Write a Python program that prompts the user for his/her amount of money, then reports how many Nintendo Wiis the person can afford, and how much more money he/she will need to afford an additional Wii.

Input: Example

```
print "What's your name?"  
name = raw_input("> ")
```

```
print "What year were you born?"  
birthyear = int(raw_input("> "))
```

```
print "Hi ", name, "! ", "You are ", 2016 - birthyear
```

```
% python input.py  
What's your name?  
> Michael  
What year were you born?  
> 1980  
Hi Michael! You are 31
```

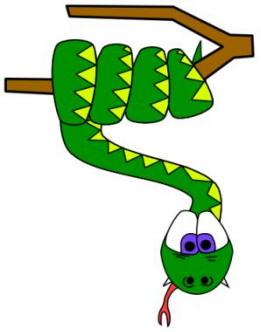

Repetition (loops) and Selection (if/else)

The for loop

- **for loop**: Repeats a set of statements over a group of values.

- Syntax:

```
for variableName in groupOfValues:  
    statements
```

- We indent the statements to be repeated with tabs or spaces.
 - **variableName** gives a name to each value, so you can refer to it in the **statements**.
 - **groupOfValues** can be a range of integers, specified with the `range` function.
- Example:

```
for x in range(1, 6):  
    print x, "squared is", x * x
```

Output:

```
1 squared is 1  
2 squared is 4  
3 squared is 9  
4 squared is 16  
5 squared is 25
```

range

- The `range` function specifies a range of integers:
 - `range(start, stop)` - the integers between **start** (inclusive) and **stop** (exclusive)
 - It can also accept a third value specifying the change between values.
 - `range(start, stop, step)` - the integers between **start** (inclusive) and **stop** (exclusive) by **step**

- **Example:**

```
for x in range(5, 0, -1):  
    print x  
print "Blastoff!"
```

Output:

```
5  
4  
3  
2  
1  
Blastoff!
```

- **Exercise:** How would we print the "99 Bottles of Beer" song?

Cumulative loops

- Some loops incrementally compute a value that is initialized outside the loop. This is sometimes called a *cumulative sum*.

```
sum = 0
for i in range(1, 11):
    sum = sum + (i * i)
print "sum of first 10 squares is", sum
```

Output:

```
sum of first 10 squares is 385
```

- **Exercise:** Write a Python program that computes the factorial of an integer.

if

- **if statement:** Executes a group of statements only if a certain condition is true. Otherwise, the statements are skipped.

- Syntax:

```
if condition:  
    statements
```

- Example:

```
gpa = 3.4  
if gpa > 2.0:  
    print "Your application is accepted."
```

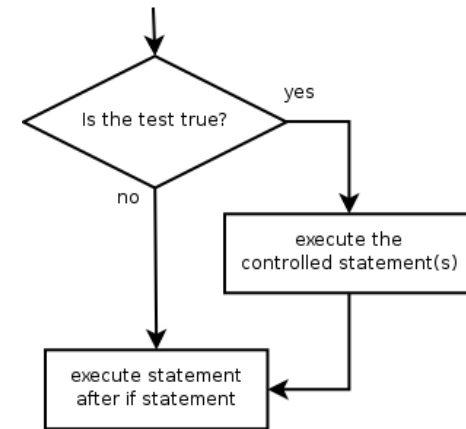

if/else

- **if/else statement:** Executes one block of statements if a certain condition is True, and a second block of statements if it is False.

- Syntax:

```
if condition:  
    statements  
else:  
    statements
```

- Example:

```
gpa = 1.4  
if gpa > 2.0:  
    print "Welcome to Mars University!"  
else:  
    print "Your application is denied."
```

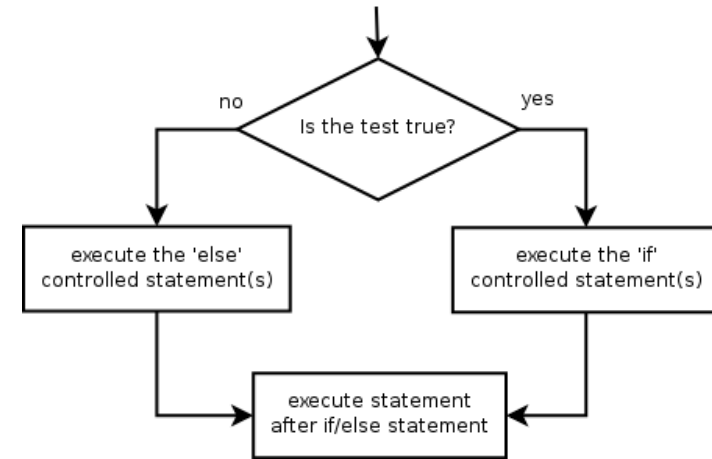

- Multiple conditions can be chained with `elif` ("else if"):

```
if condition:  
    statements  
elif condition:  
    statements  
else:  
    statements
```

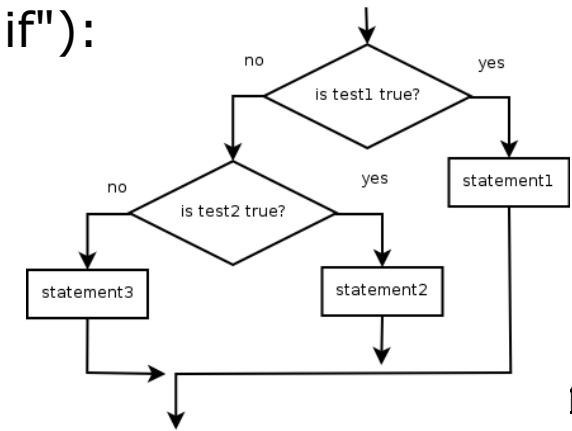

Example of If Statements

```
import math
x = 30
if x <= 15 :
    y = x + 15
elif x <= 30 :
    y = x + 30
else :
    y = x
print `y = `,
print math.sin(y)
```

In file ifstatement.py

```
>>> import ifstatement
y = 0.999911860107
>>>
```

In interpreter

while

- **while loop:** Executes a group of statements as long as a condition is True.
 - good for *indefinite loops* (repeat an unknown number of times)

- **Syntax:**

```
while condition:  
    statements
```

- **Example:**

```
number = 1  
while number < 200:  
    print number,  
    number = number * 2
```

- **Output:**

```
1 2 4 8 16 32 64 128
```

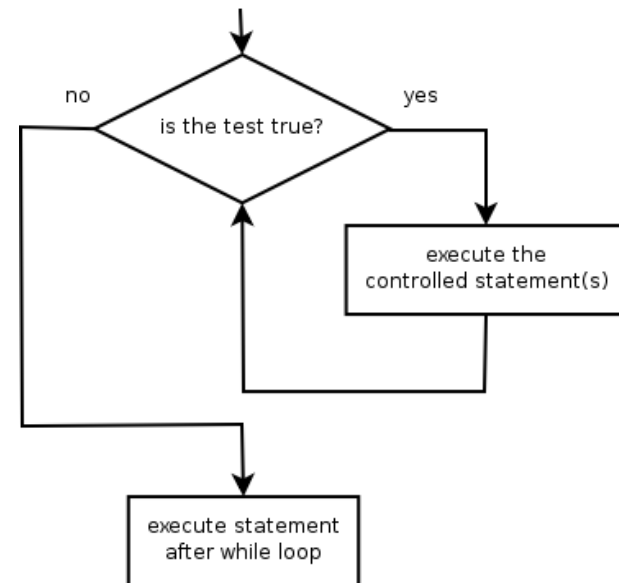

While Loops

```
x = 1
while x < 10 :
    print x
    x = x + 1
```

- In whileloop.py

```
>>> import whileloop
1
2
3
4
5
6
7
8
9
>>>
```

- In interpreter

Logic

- Many logical expressions use *relational operators*:

Operator	Meaning	Example	Result
==	equals	<code>1 + 1 == 2</code>	True
!=	does not equal	<code>3.2 != 2.5</code>	True
<	less than	<code>10 < 5</code>	False
>	greater than	<code>10 > 5</code>	True
<=	less than or equal to	<code>126 <= 100</code>	False
>=	greater than or equal to	<code>5.0 >= 5.0</code>	True

- Logical expressions can be combined with *logical operators*:

Operator	Example	Result
and	<code>9 != 6 and 2 < 3</code>	True
or	<code>2 == 3 or -1 < 5</code>	True
not	<code>not 7 > 0</code>	False

- Exercise:** Write code to display and count the factors of a number.

Loop Control Statements

break	Jumps out of the closest enclosing loop
continue	Jumps to the top of the closest enclosing loop
pass	Does nothing, empty statement placeholder

More Examples For Loops

- Similar to perl for loops, iterating through a list of values

forloop1.py

```
for x in [1,7,13,2]:  
    print x
```

```
%python forloop1.py  
1  
7  
13  
2
```

forloop2.py

```
for x in range(5) :  
    print x
```

```
% python forloop2.py  
0  
1  
2  
3  
4
```

range(N) generates a list of numbers [0,1, ..., n-1]

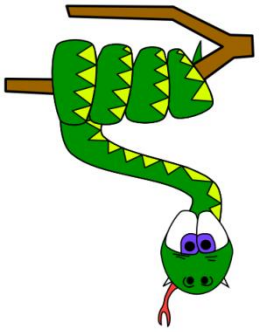

More Data Types

Everything is an object

- Everything means everything, including functions and classes (more on this later!)
- Data type is a property of the object and not of the variable

```
>>> x = 7
>>> x
7
>>> x = 'hello'
>>> x
'hello'
>>>
```

Numbers: Integers

- Integer – the equivalent of a C long
- Long Integer – an unbounded integer value.

```
>>> 132224
132224
>>> 132323 **
2
17509376329L
>>>
```

Numbers: Floating Point

- `int(x)` converts `x` to an integer
- `float(x)` converts `x` to a floating point
- The interpreter shows a lot of digits

```
>>> 1.23232
1.232320000000000001
>>> print 1.23232
1.23232
>>> 1.3E7
13000000.0
>>> int(2.0)
2
>>> float(2)
2.0
```

Numbers: Complex

- Built into Python
- Same operations are supported as integer and float

```
>>> x = 3 + 2j
>>> y = -1j
>>> x + y
(3+1j)
>>> x * y
(2-3j)
```

String Literals

- + is overloaded to do concatenation

```
>>> x = 'hello'  
>>> x = x + ' there'  
>>> x  
'hello there'
```

String Literals

- Can use single or double quotes, and three double quotes for a multi-line string

```
>>> 'I am a string'
```

```
'I am a string'
```

```
>>> "So am I!"
```

```
'So am I!'
```

Substrings and Methods

```
>>> s = '012345'  
>>> s[3]  
'3'  
>>> s[1:4]  
'123'  
>>> s[2:]  
'2345'  
>>> s[:4]  
'0123'  
>>> s[-2]  
'4'
```

- **len**(String) – returns the number of characters in the String
- **str**(Object) – returns a String representation of the Object

```
>>> len(x)  
6  
>>>  
str(10.3)  
'10.3'
```

String Formatting

- Similar to C's printf
- <formatted string> % <elements to insert>
- Can usually just use %s for everything, it will convert the object to its String representation.

```
>>> "One, %d, three" % 2
'One, 2, three'
>>> "%d, two, %s" % (1,3)
'1, two, 3'
>>> "%s two %s" % (1, 'three')
'1 two three'
>>>
```

Types for Data Collection List, Set, and Dictionary

List

Indexes Values

0	Six Eggs
1	Milk
2	Flour
3	Baking Powder
4	Bananas

Ordered

Set

Values

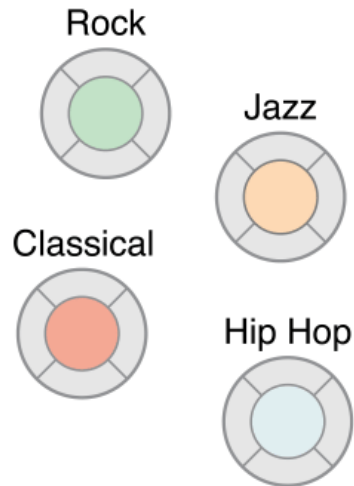

Unordered list

Dictionary

Keys

Values

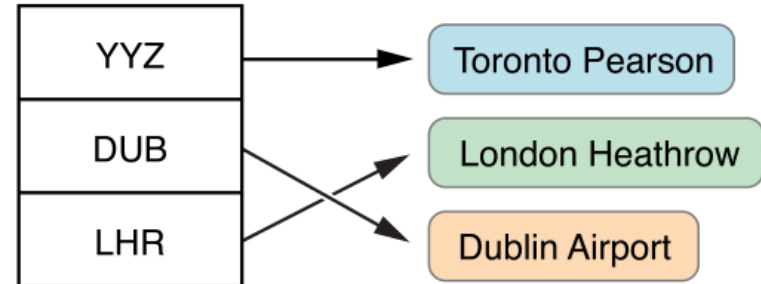

Pairs of values

Lists

- Ordered collection of data
- Data can be of different types
- Lists are *mutable*
- Issues with shared references and mutability
- Same subset operations as Strings

```
>>> x = [1,'hello', (3 + 2j)]
>>> x
[1, 'hello', (3+2j)]
>>> x[2]
(3+2j)
>>> x[0:2]
[1, 'hello']
```

List Functions

- `list.append(x)`
 - Add item at the end of the list.
- `list.insert(i,x)`
 - Insert item at a given position.
 - Similar to `a[i:i]=[x]`
- `list.remove(x)`
 - Removes first item from the list with value `x`
- `list.pop(i)`
 - Remove item at position `I` and return it. If no index `I` is given then remove the first item in the list.
- `list.index(x)`
 - Return the index in the list of the first item with value `x`.
- `list.count(x)`
 - Return the number of time `x` appears in the list
- `list.sort()`
 - Sorts items in the list in ascending order
- `list.reverse()`
 - Reverses items in the list

Lists: Modifying Content

- **x[i] = a** reassigns the *i*th element to the value *a*
- Since *x* and *y* point to the same list object, *both* are changed
- The method **append** also modifies the list

```
>>> x = [1,2,3]
>>> y = x
>>> x[1] = 15
>>> x
[1, 15, 3]
>>> y
[1, 15, 3]
>>> x.append(12)
>>> y
[1, 15, 3, 12]
```

Lists: Modifying Contents

- The method **append** modifies the list and returns **None**
- List addition (**+**) returns a new list

```
>>> x = [1,2,3]
>>> y = x
>>> z = x.append(12)
>>> z == None
True
>>> y
[1, 2, 3, 12]
>>> x = x + [9,10]
>>> x
[1, 2, 3, 12, 9, 10]
>>> y
[1, 2, 3, 12]
>>>
```

Using Lists as Stacks

- You can use a list as a stack

```
>>> a = ["a", "b", "c", "d"]
```

```
>>> a
```

```
['a', 'b', 'c', 'd']
```

```
>>> a.append("e")
```

```
>>> a
```

```
['a', 'b', 'c', 'd', 'e']
```

```
>>> a.pop()
```

```
'e'
```

```
>>> a.pop()
```

```
'd'
```

```
>>> a = ["a", "b", "c"]
```

```
>>>
```

Tuples

- Tuples are *immutable* versions of lists
- One strange point is the format to make a tuple with one element:
' ,' is needed to differentiate from the mathematical expression (2)

```
>>> x = (1,2,3)
>>> x[1:]
(2, 3)
>>> y = (2,)
>>> y
(2,)
>>>
```



Sets

- A set is another python data structure that is an unordered collection with no duplicates.

```
>>> setA=set(["a","b","c","d"])
```

```
>>> setB=set(["c","d","e","f"])
```

```
>>> "a" in setA
```

```
True
```

```
>>> "a" in setB
```

```
False
```

Sets

```
>>> setA - setB
```

```
{'a', 'b'}
```

```
>>> setA | setB
```

```
{'a', 'c', 'b', 'e', 'd', 'f'}
```

```
>>> setA & setB
```

```
{'c', 'd'}
```

```
>>> setA ^ setB
```

```
{'a', 'b', 'e', 'f'}
```

```
>>>
```

Dictionaries

- A set of key-value pairs
- Dictionaries are *mutable*

```
>>> d= {'one' : 1, 'two' : 2, 'three' : 3}
>>> d['three']
3
```

Dictionaries: Add/Modify

- Entries can be changed by assigning to that entry

```
>>> d
{1: 'hello', 'two': 42, 'blah': [1, 2, 3]}
>>> d['two'] = 99
>>> d
{1: 'hello', 'two': 99, 'blah': [1, 2, 3]}
```

- Assigning to a key that does not exist adds an entry

```
>>> d[7] = 'new entry'
>>> d
{1: 'hello', 7: 'new entry', 'two': 99, 'blah': [1, 2, 3]}
```

Dictionaries: Deleting Elements

- The **del** method deletes an element from a dictionary

```
>>> d
{1: 'hello', 2: 'there', 10: 'world'}
>>> del(d[2])
>>> d
{1: 'hello', 10: 'world'}
```



Iterating over a dictionary

```
>>> address={'Wayne': 'Young 678', 'John': 'Oakwood 345',  
            'Mary': 'Kingston 564'}  
>>> for k in address.keys():  
        print(k,":", address[k])
```

```
Wayne : Young 678  
John : Oakwood 345  
Mary : Kingston 564  
>>>
```

```
>>> for k in sorted(address.keys()):  
        print(k,":", address[k])
```

```
John : Oakwood 345  
Mary : Kingston 564  
Wayne : Young 678  
>>>
```



Copying Dictionaries and Lists

- The built-in **list** function will copy a list
- The dictionary has a method called **copy**

```
>>> l1 = [1]
>>> l2 = list(l1)
>>> l1[0] = 22
>>> l1
[22]
>>> l2
[1]
```

```
>>> d = {1 : 10}
>>> d2 = d.copy()
>>> d[1] = 22
>>> d
{1: 22}
>>> d2
{1: 10}
```

Data Type Summary

Integers: 2323, 3234L

Floating Point: 32.3, 3.1E2

Complex: 3 + 2j, 1j

Lists: l = [1,2,3]

Tuples: t = (1,2,3)

Dictionaries: d = {'hello' : 'there', 2 : 15}

- Lists, Tuples, and Dictionaries can store any type (including other lists, tuples, and dictionaries!)
- Only lists and dictionaries are mutable
- All variables are references

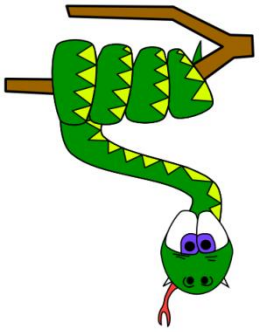

Functions

Function Basics

```
def max(x,y) :  
    if x < y :  
        return x  
    else :  
        return y
```

functionbasics.py

```
>>> import functionbasics  
>>> max(3,5)  
5  
>>> max('hello', 'there')  
'there'  
>>> max(3, 'hello')  
'hello'
```

Functions are objects

- Can be assigned to a variable
- Can be passed as a parameter
- Can be returned from a function
- Functions are treated like any other variable in Python, the **def** statement simply assigns a function to a variable

Function names are like any variable

- Functions are objects
- The same reference rules hold for them as for other objects

```
>>> x = 10
>>> x
10
>>> def x () :
...     print 'hello'
>>> x
<function x at 0x619f0>
>>> x()
hello
>>> x = 'blah'
>>> x
'blah'
```

Functions as Parameters

```
def foo(f, a) :  
    return f(a)  
  
def bar(x) :  
    return x * x
```

funcasparam.py

```
>>> from funcasparam import *  
>>> foo(bar, 3)  
9
```

- Note that the function **foo** takes two parameters and applies the first as a function with the second as its parameter

Higher-Order Functions

- **map(func,seq)** – for all i, applies func(seq[i]) and returns the corresponding sequence of the calculated results.

```
def double(x):  
    return 2*x
```

highorder.py

```
>>> from highorder import *  
>>> lst = range(10)  
>>> lst  
[0,1,2,3,4,5,6,7,8,9]  
>>> map(double,lst)  
[0,2,4,6,8,10,12,14,16,18]
```

Higher-Order Functions

- **filter(boolfunc,seq)** – returns a sequence containing all those items in seq for which boolfunc is True.

```
def even(x):  
    return ((x%2 ==  
0)
```

highorder.py

```
>>> from highorder import *  
>>> lst = range(10)  
>>> lst  
[0,1,2,3,4,5,6,7,8,9]  
>>> filter(even,lst)  
[0,2,4,6,8]
```

Higher-Order Functions

- **reduce(func,seq)** – applies func to the items of seq, from left to right, two-at-time, to reduce the seq to a single value.

```
def plus(x,y):  
    return (x + y)
```

highorder.py

```
■ >>> from highorder import *  
■ >>> lst = ['h','e','l','l','o']  
■ >>> reduce(plus,lst)  
■ 'hello'
```

Functions Inside Functions

- Since they are like any other object, you can have functions inside functions

```
def foo (x,y) :  
    def bar (z) :  
        return z * 2  
    return bar(x) + y
```

```
>>> from funcinfunc import *  
>>> foo(2,3)  
7
```

funcinfunc.py

Functions Returning Functions

```
def foo (x) :  
    def bar(y) :  
        return x + y  
    return bar  
# main  
f = foo(3)  
print f  
print f(2)
```

```
% python funcreturnfunc.py  
<function bar at 0x612b0>  
5
```

funcreturnfunc.py

Parameters: Defaults

- Parameters can be assigned default values
- They are overridden if a parameter is given for them
- The type of the default doesn't limit the type of a parameter

```
■ >>> def foo(x = 3) :  
■ ...     print x  
■ ...  
■ >>> foo()  
■ 3  
■ >>> foo(10)  
■ 10  
■ >>> foo('hello')  
■ hello
```

Parameters: Named

- Call by name
- Any positional arguments must come before named ones in a call

```
>>> def foo (a,b,c) :  
...     print a, b, c  
...  
>>> foo(c = 10, a = 2, b = 14)  
2 14 10  
>>> foo(3, c = 2, b = 19)  
3 19 2
```

Anonymous Functions

- A lambda expression returns a function object
- The body can only be a simple expression, not complex statements

```
>>> f = lambda x,y : x + y
>>> f(2,3)
5
>>> lst = ['one', lambda x : x * x, 3]
>>> lst[1](4)
16
```

Modules

- The highest level structure of Python
- Each file with the py suffix is a module
- Each module has its own namespace

Modules: Imports

<code>import mymodule</code>	Brings all elements of mymodule in, but must refer to as mymodule.<elem>
<code>from mymodule import x</code>	Imports x from mymodule right into this namespace
<code>from mymodule import *</code>	Imports all elements of mymodule into this namespace

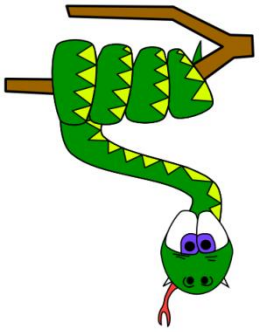

Text and File Processing

Strings

- **string**: A sequence of text characters in a program.
 - Strings start and end with quotation mark " or apostrophe ' characters.
 - Examples:

```
"hello"  
"This is a string"  
"This, too, is a string.    It can be very long!"
```
- A string may not span across multiple lines or contain a " character.

```
"This is not  
a legal String."  
"This is not a "legal" String either."
```
- A string can represent characters by preceding them with a backslash.
 - \t tab character
 - \n new line character
 - \" quotation mark character
 - \\ backslash character
 - Example: "Hello\tthere\nHow are you?"

Indexes

- Characters in a string are numbered with *indexes* starting at 0:

- Example:

```
name = "P. Diddy"
```

index	0	1	2	3	4	5	6	7
character	P	.		D	i	d	d	y

- Accessing an individual character of a string:

variableName [***index***]

- Example:

```
print name, "starts with", name[0]
```

Output:

```
P. Diddy starts with P
```

String properties

- `len(string)` - number of characters in a string (including spaces)
- `str.lower(string)` - lowercase version of a string
- `str.upper(string)` - uppercase version of a string

■ Example:

```
name = "Martin Douglas Stepp"  
length = len(name)  
big_name = str.upper(name)  
print big_name, "has", length, "characters"
```

Output:

```
MARTIN DOUGLAS STEPP has 20 characters
```

raw_input

- `raw_input` : Reads a string of text from user input.

- Example:

```
name = raw_input("Howdy, pardner. What's yer name? ")
print name, "... what a silly name!"
```

Output:

```
Howdy, pardner. What's yer name? Paris Hilton
Paris Hilton ... what a silly name!
```

Text processing

- **text processing:** Examining, editing, formatting text.
 - often uses loops that examine the characters of a string one by one
- A `for` loop can examine each character in a string in sequence.
 - Example:

```
for c in "booyah":  
    print c
```

Output:

```
b  
o  
o  
y  
a  
h
```

Strings and numbers

- `ord(text)` - converts a string into a number.
 - Example: `ord("a")` is 97, `ord("b")` is 98, ...
 - Characters map to numbers using standardized mappings such as *ASCII* and *Unicode*.
- `chr(number)` - converts a number into a string.
 - Example: `chr(99)` is "c"
- **Exercise:** Write a program that performs a rotation cypher.
 - e.g. "Attack" when rotated by 1 becomes "buubdl"

File processing

- Many programs handle data, which often comes from files.
- Reading the entire contents of a file:

```
variableName = open ("filename") .read()
```

Example:

```
file_text = open("bankaccount.txt").read()
```

Line-by-line processing

- Reading a file line-by-line:

```
for line in open("filename").readlines():  
    statements
```

Example:

```
count = 0  
for line in open("bankaccount.txt").readlines():  
    count = count + 1  
print "The file contains", count, "lines."
```

- **Exercise:** Write a program to process a file of DNA text, such as:
 ATGCAATTGCTCGATTAG
 - Count the percent of C+G present in the DNA.

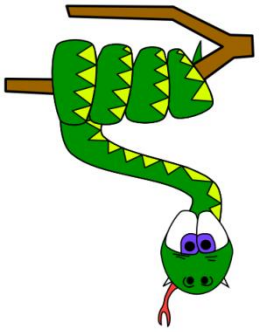

Objects and Classes

Defining a Class

- Python program may own many objects
 - An object is an item with fields supported by a set of method functions.
 - An object can have several fields (or called attribute variables) describing such an object
 - These fields can be accessed or modified by object methods
 - A class defines what objects look like and what functions can operate on these object.

■ Declaring a class:

```
class name:  
    statements
```

■ Example:

```
class UCSBstudent:  
    age = 21  
    schoolname= 'UCSB'
```

Fields

name = value

- Example:

```
class Point:  
    x = 0  
    y = 0
```

```
# main
```

```
p1 = Point()  
p1.x = 2  
p1.y = -5
```

point.py

```
1 class Point:  
2     x = 0  
3     y = 0
```

- can be declared directly inside class (as shown here) or in constructors (more common)
- Python does not really have encapsulation or private fields
 - relies on caller to "be nice" and not mess with objects' contents

Using a Class

import **class**

- client programs must import the classes they use

point_main.py

```
1  from Point import *
2
3  # main
4  p1 = Point()
5  p1.x = 7
6  p1.y = -3
7
8  p2 = Point()
9  p2.x = 7
10 p2.y = 1

# Python objects are dynamic (can add fields any time!)
p1.name = "Tyler Durden"
```

Object Methods

```
def name(self, parameter, ..., parameter):  
    statements
```

- `self` *must* be the first parameter to any object method
 - represents the "implicit parameter" (`this` in Java)
- *must* access the object's fields through the `self` reference

```
class Point:  
    def move(self, dx, dy):  
        self.x += dx  
        self.y += dy
```

Exercise Answer

point.py

```
1  from math import *
2
3  class Point:
4      x = 0
5      y = 0
6
7      def set_location(self, x, y):
8          self.x = x
9          self.y = y
10
11     def distance_from_origin(self):
12         return sqrt(self.x * self.x + self.y * self.y)
13
14     def distance(self, other):
15         dx = self.x - other.x
16         dy = self.y - other.y
17         return sqrt(dx * dx + dy * dy)
```

Calling Methods

- A client can call the methods of an object in two ways:
 - (the value of `self` can be an implicit or explicit parameter)

1) **object.method (parameters)**

or

2) **Class.method (object, parameters)**

- Example:

```
p = Point(3, -4)
```

```
p.move(1, 5)
```

```
Point.move(p, 1, 5)
```

Constructors

```
def __init__(self, parameter, ..., parameter):  
    statements
```

- a constructor is a special method with the name `__init__`
- Example:

```
class Point:  
    def __init__(self, x, y):  
        self.x = x  
        self.y = y  
    ...
```

- How would we make it possible to construct a `Point()` with no parameters to get `(0, 0)`?

toString and `__str__`

```
def __str__(self):  
    return string
```

- equivalent to Java's `toString` (converts object to a string)
- invoked automatically when `str` or `print` is called

Exercise: Write a `__str__` method for `Point` objects that returns strings like `"(3, -14)"`

```
def __str__(self):  
    return "(" + str(self.x) + ", " + str(self.y) + ")"
```

Complete Point Class

point.py

```
1  from math import *
2
3  class Point:
4      def __init__(self, x, y):
5          self.x = x
6          self.y = y
7
8      def distance_from_origin(self):
9          return sqrt(self.x * self.x + self.y * self.y)
10
11     def distance(self, other):
12         dx = self.x - other.x
13         dy = self.y - other.y
14         return sqrt(dx * dx + dy * dy)
15
16     def move(self, dx, dy):
17         self.x += dx
18         self.y += dy
19
20     def __str__(self):
21         return "(" + str(self.x) + ", " + str(self.y) + ")"
```

Operator Overloading

- **operator overloading**: You can define functions so that Python's built-in operators can be used with your class.
 - See also: <http://docs.python.org/ref/customization.html>

Operator	Class Method
-	<code>__neg__(self, other)</code>
+	<code>__pos__(self, other)</code>
*	<code>__mul__(self, other)</code>
/	<code>__truediv__(self, other)</code>

■ Unary Operators

-	<code>__neg__(self)</code>
+	<code>__pos__(self)</code>

Operator	Class Method
==	<code>__eq__(self, other)</code>
!=	<code>__ne__(self, other)</code>
<	<code>__lt__(self, other)</code>
>	<code>__gt__(self, other)</code>
<=	<code>__le__(self, other)</code>
>=	<code>__ge__(self, other)</code>

Generating Exceptions

```
raise ExceptionType("message")
```

- useful when the client uses your object improperly
- **types:** `ArithmeticError`, `AssertionError`, `IndexError`, `NameError`, `SyntaxError`, `TypeError`, `ValueError`

- **Example:**

```
class BankAccount:  
    ...  
    def deposit(self, amount):  
        if amount < 0:  
            raise ValueError("negative amount")  
        ...
```

Inheritance

```
class name (superclass) :  
    statements
```

- Example:

```
class Point3D(Point) :      # Point3D extends Point  
    z = 0  
    ...
```

- Python also supports *multiple inheritance*

```
class name (superclass, ..., superclass) :  
    statements
```

(if > 1 superclass has the same field/method, conflicts are resolved in left-to-right order)

Calling Superclass Methods

- methods: **class.method(object, parameters)**
- constructors: **class.__init__(parameters)**

```
class Point3D(Point):  
    z = 0  
    def __init__(self, x, y, z):  
        Point.__init__(self, x, y)  
        self.z = z  
  
    def move(self, dx, dy, dz):  
        Point.move(self, dx, dy)  
        self.z += dz
```